

Bevent Rasch

- Fire -

BSKC6

13/09/17



CE

Fire damper BSKC6

- Fire resistance class EI60/EI60S
- Sizes from 100 mm to 630 mm
- Prefitted safety actuator 24V or 230V
- Low weight
- Easy installation
- CE-marked building product according to 15650:2010
- Available in MagiCAD



Quick facts

- Fire resistance class EI60/EI60S
- Sizes from 100 mm to 630 mm
- Prefitted safety actuator 24V or 230V
- Low weight
- Easy installation
- CE-marked building product according to 15650:2010
- Available in MagiCAD

Use

Damper in combination with walls or floor systems for fire separation of heating, ventilation and air conditioning installations in buildings. In accordance with the harmonised European standard EN 15650:2010. In designs according to associated documents, installation instructions and when the damper is used in combination with smoke detectors and monitoring system (MRB), or the like, the spread of fire/combustion gases is prevented. No further action against the spread of fire/combustion gases is required.

Performance

EC certificate according to EN 15650:2010

402-CPD-SC0900-13

Classification of fire resistance according to EN 13501-3

EI60 (ve ho i <-> o) S

For complete classification, see the Declaration of Performance.



Installation

BSKC6 is installed in fire cell separating walls or floor systems, alternatively in horizontal insulated ducts going through fire cell separating building elements, according to the adjoining installation instructions. Should not be installed outdoors or in damp areas.

Actuator

BSKC6 is always supplied with an electric safety actuator with spring return complete with thermal sensor with pushbutton for local manual operating test. The sensor disconnects the power to the actuator if the temperature exceeds 72 °C inside or outside the damper. 24V actuators are always used in connection with the MRB monitoring system. Dampers can also be supplied with electric actuator 230V.

Note that the BSKC6 damper is always supplied with an actuator.

Activation

According to Boverket's Building Regulations smoke detectors must be verified according to SS-EN 54-7 to activate dampers. The mandatory thermal sensor closes the damper at 72 °C according to ISO 10294-4.

Control and monitoring

When the damper is used to prevent the spread of fire and combustion gases it must be closed via impulses from the smoke detector. This must be fitted in the ventilation duct in the proximity of the damper or in another suitable location. Smoke detectors are monitored by means of Rasch's MRB system or the like. The MRB monitoring system also performs automatic operating checks on the damper every 48 hours and is designed so that faults are indicated immediately and the damper closes.

See www.bevent-rasch.com for further details.

Size Ø100-630 mm.

Design

BSKC6 is supplied complete with factory mounted, maintenance-free, 24V electric safety actuator with thermal sensor featuring built-in signal contacts to indicate the damper position. Spiral duct connections.

Material and surface finish

Casing and components of galvanized steel sheet according to environmental class C3. Fabric seals. EPDM spiral duct connections. Blade and casing of solid fire protection materials.

Accessories

BRMK	Installation kit
BRTO	Wire mesh grille
RCKB	Connection box
RCDU	MRB system, max 2 dampers
RCBK4	MRB system, max 4 dampers
RCMU8	MRB system, max 8 dampers
RCKD/-RD	Smoke detectors
RCTU/RCTC	MRB3 system, max 236 dampers

Specification

Example:

Fire damper **BSKC6 - 400 - 1 - 1**

Size, nom. diameter ØD mm

Material

Galvanized sheet steel = 1

Stainless AISI 3041 – EN 1.4301 = 2

Stainless AISI 316L – EN 1.4404 = 3

Actuator

Electric 24V with thermal sensor = 1

Electric 230V with thermal sensor = 3

Electric 24V incl. RCTU = 5

Note. Factory fitted actuator always included.

Dimensions and weight

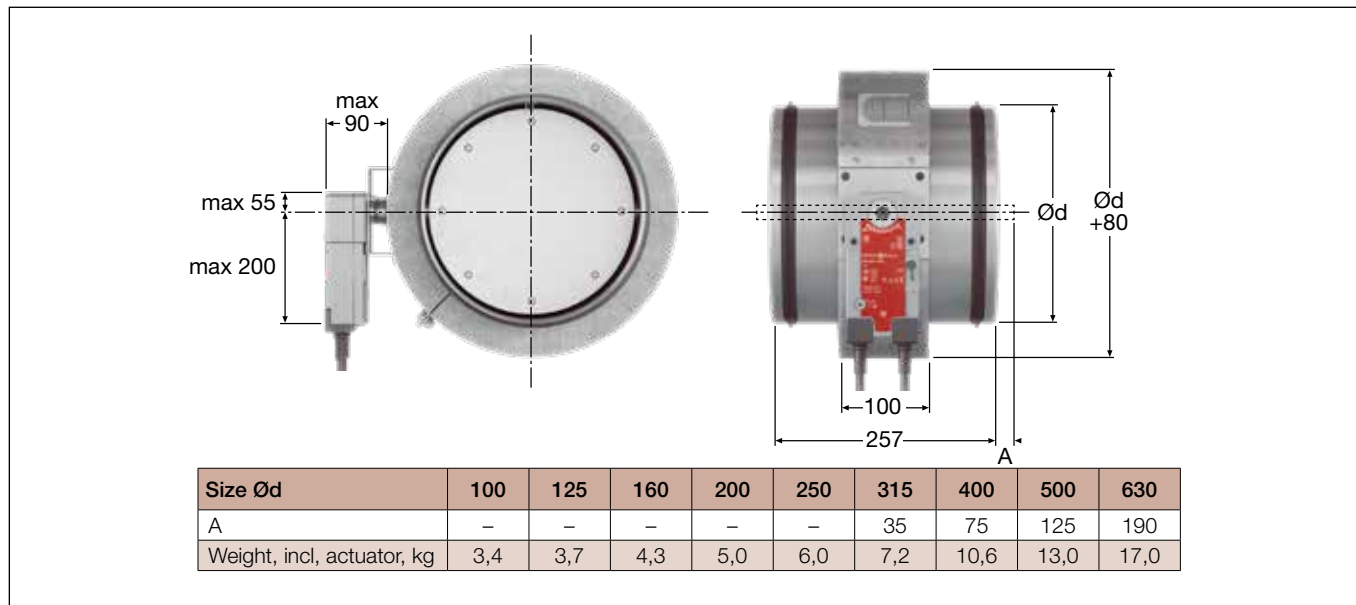

Actuator - damper sizes

Actuator BLF-T is supplied to damper sizes Ø100-315 mm.
 Actuator BF-T is supplied to damper sizes Ø400-630 mm.

Electrical data (values in brackets refer to 230V)

	Actuator type BF..	BLF..
Sizing, max	10 VA (12.5 VA)	7 VA (7 VA)
Running time:		
- motor opening, max	approx. 120 s	40-75 s
- spring return, max	approx. 20 s	
Protection class	IP 54	
Power supply	24V~ ±20%, 50/60Hz	24V= ±10%
	(220-240V~ , 50/60Hz)	
Ambient temperature	-30° to +50°C	
Safety temperature	-30° to +75°C	
	(24 hrs. guaranteed safety)	
Tripping temperature thermal sensor	72°C	
End position contacts		
- load ≤ 300 mW	min 1 mA/5V=, max 100 mA/250V~	
After exceeding the above values it applies:		
- load > 300 mW	min 100 mA, max 3 A/250~	
Sound level when opening	approx 45 dB(A)	
Sound level when closing	approx 62 dB(A)	

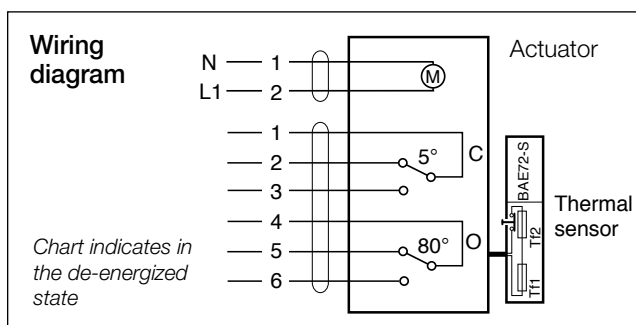

Size chart

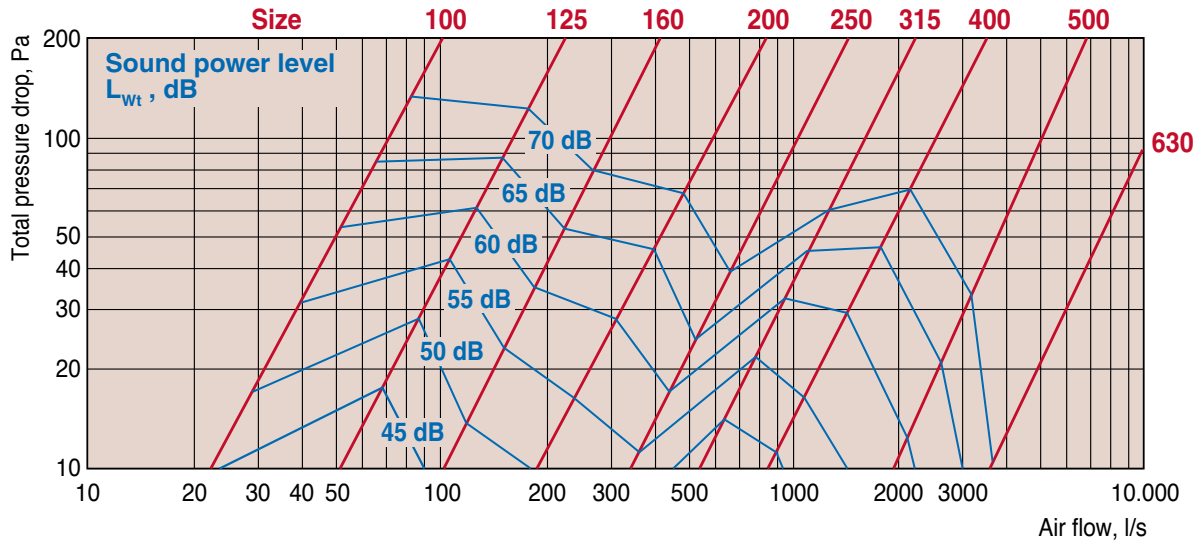

Sound data

Correction of sound power level, L_{Wok} , in octave band

$$L_{Wok} = L_w + K_{ok}$$

Correction, K_{ok}

Size Ø mm	Centre Frequency Hz							
	63	125	250	500	1000	2000	4000	8000
100	-4	-6	-7	-12	-17	-24	-26	-33
125	-5	-5	-8	-14	-22	-25	-27	-35
160	-5	-4	-8	-13	-17	-20	-28	-34
200	-3	-6	-10	-14	-15	-19	-27	-40
250	-1	-11	-15	-20	-22	-23	-29	-37
315	-2	-8	-11	-12	-13	-19	-23	-29
400	-2	-8	-14	-12	-15	-22	-30	-41
500	-2	-8	-13	-13	-15	-21	-28	-36
630	0	-15	-23	-23	-28	-35	-41	-48
Tol. ± dB	2	3	4	4	6	7	9	9

Installation instruction

Supporting construction (wall or floor) in fire resistance class EI60.
 Damper's fire resistance class: EI60 (ve ho i <-> o) S.
 EC certificate 0402-CPD-SC0900-13

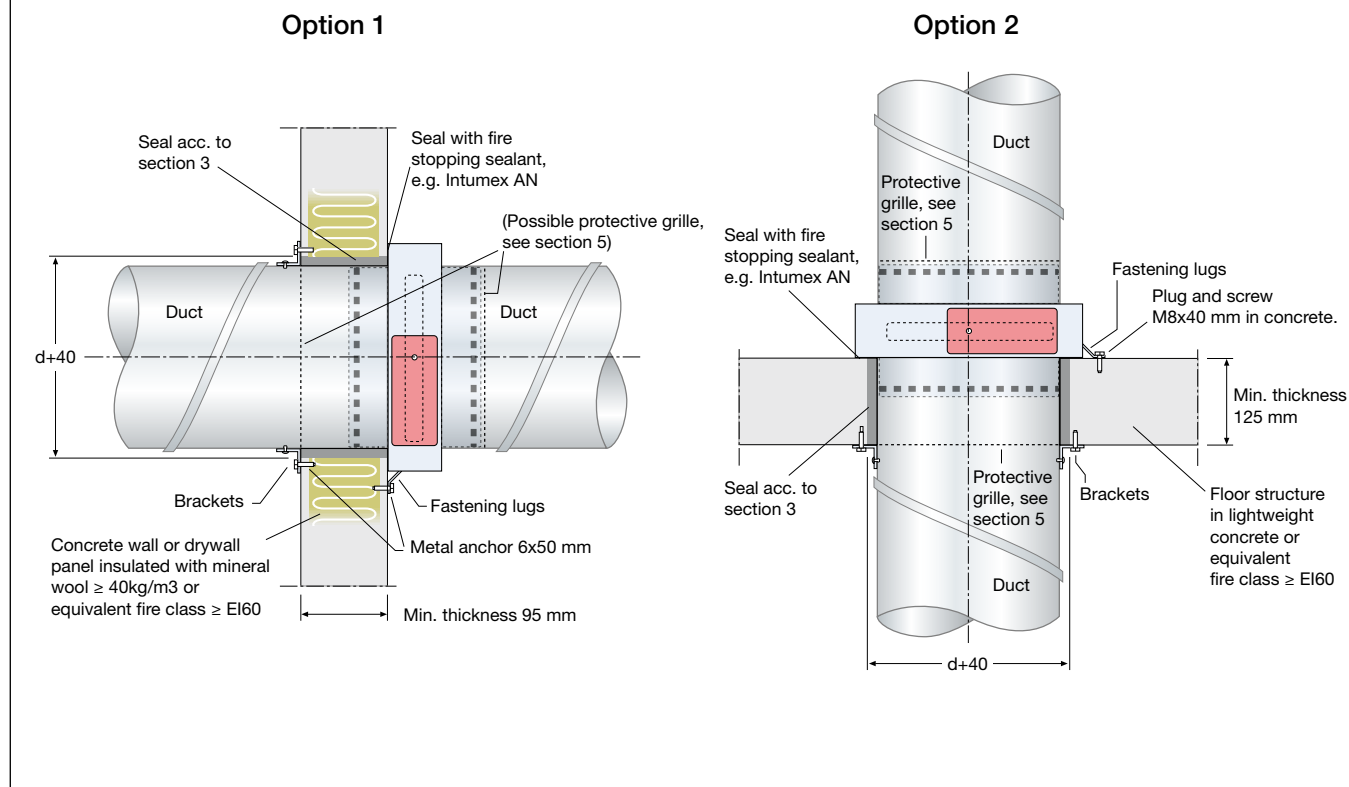

Options 1 and 2

1. Install and join the damper in the ventilation duct that ends at the wall or floor face (after the lead-through).
2. The damper is secured flat and tight using fire stopping sealant (Intumex AN) against the wall/floor structure with the fastening lugs, which are opened out.
3. Sealing is carried out by caulking with mineral wool, min 40 kg/m³.
4. Use brackets to fasten the duct to the wall.
5. If fire damper is not connected to the duct system, fit non-combustible grilles designed for the damper on the unconnected sides. The minimum distance between the damper blade in the open position and the grille is 50 mm.
6. Install the thermal sensor with the sensor body in the air flow without obstructing the movement of the damper blade.
7. Install the duct system according to applicable requirements.
 - Minimum distance between dampers must be 200 mm.
 - Minimum distance to joist structure/wall must be 75 mm.

Installation instruction

Installation in horizontal duct.
Damper's fire resistance class: EI60 (ve i <-> o) S.
EC certificate 0402-CPD-SC0900-13

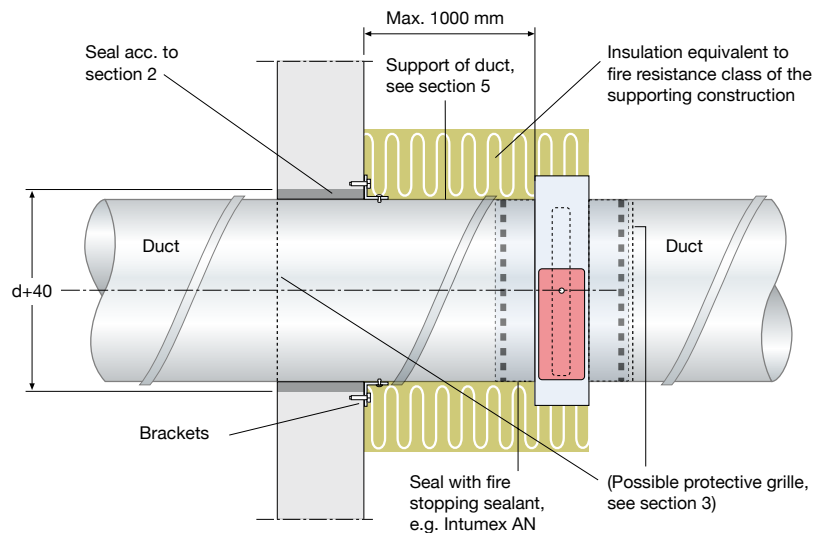

1. Install the damper in the duct.
2. Duct going through supporting construction, is fastened using brackets. Seal according to applicable requirements, such as caulking with mineral wool, min 40 kg/m³ and fire stopping sealant.
3. If fire damper is not connected to the duct system, fit non-combustible grilles designed for the damper on the unconnected sides. The minimum distance between the damper blade in the open position and the grille is 50 mm.
4. Install the thermal sensor with the sensor body in the air flow without obstructing the movement of the damper blade.
5. Duct is fastened/supported according to applicable requirements.
6. Insulate the duct according to applicable requirements using instructions from the insulation supplier, min. 80 mm and 55 kg/m³. Note that insulation must cover the damper.
 - *Minimum distance between dampers must be 200 mm.*
 - *Minimum distance to joist structure/wall must be 75 mm.*
 - *The damper spindle may be installed in any position.*