

RABC

Circular fire damper



FIRE SAFETY



CE

18/03/2025



Quick facts

- Fire resistance class E60/E120S
- Sizes from 100 mm to 630 mm
- Prefitted safety actuator 24V or 230V
- Installation in ducts
- Available in MagiCAD
- CE-marked building product according to 15650:2010

Use

Damper in combination with walls or joist systems for fire separation of heating, ventilation and air conditioning installations in buildings. In accordance with the harmonised European standard EN 15650:2010. In designs according to associated documents, installation instructions and when the damper is used in combination with smoke detectors and monitoring system (MRB), or the like, the spread of combustion gases is prevented. No further action against the spread of combustion gases is required.

Performance

EC certificate according to EN 15650:2010
402-CPD-SC0058-13

Classification of fire resistance according to EN 13501-3

E120 (ve i <-> o) S
E120 (ve ho i <-> o)
E60 (ve ho i <-> o)



Installation

RABC is installed in horizontal or vertical ducts that pass through fire cell separating building elements, according to the adjoining installation instructions.

Actuator

RABC is always supplied with an electric safety actuator with spring return complete with thermal sensor with pushbutton for local manual operating test. The sensor disconnects the power to the actuator if the temperature exceeds 72°C inside or outside the damper. 24V actuators are always used in connection with the MRB monitoring system. Dampers can also be supplied with electric actuator 230V.

Note that the RABC damper is always supplied with an actuator.

Activation

The mandatory thermal sensor closes the damper at 72 °C according to ISO 10294-4.

Control and monitoring

When the damper is used to prevent the spread of fire and combustion gases it must be closed via impulses from the smoke detector. This must be fitted in the ventilation duct in the proximity of the damper or in another suitable location. Smoke detectors are monitored by means of Rasch's MRB system or the like. The MRB monitoring system also performs automatic operating checks on the damper every 48 hours and is designed so that faults are indicated immediately and the damper closes.

See www.bevent-rasch.com for further details.



Size Ø100-630 mm

Design

RABC is supplied complete with factory mounted, maintenance-free, 24V electric safety actuator with thermal sensor featuring built-in signal contacts to indicate the damper position. Spiral duct connections.

Material and surface finish

Casing and components of aluzink AZ185 according to environmental class C4 in sizes 100 mm-315 mm. Casing and components of galvanized steel sheet according to environmental class C3 in sizes 400 mm-630 mm. Fabric seals. EPDM spiral duct connections.

Accessories

RCKB	Connection box
RCDU	MRB system, max 2 dampers
RCBK4	MRB system, max 4 dampers
RCMU8	MRB system, max 8 dampers
RCKD/-RD	Smoke detectors
RCTU/RCTC	MRB3 system, max 236 dampers
FENIX2	max 2 dampers
FENIX4 / FENIX+	max 16 dampers

Specification

Example:

Fire damper **RABC - 400 - 1 - 1**

Size, nom. diameter ØD mm —————

Material

Galvanized sheet steel = 1

Stainless AISI 316L – EN 1.4404 = 3

Actuator

Electric 24V with thermal sensor = 1

Electric 230V with thermal sensor = 3

Electric 24V incl. RCTU = 5

Note. Factory fitted actuator always included.



Dimensions and weight

Size Ø mm	Spiral			Weight, kg
	A	B	C	
100	120	200	-	2.8
125	120	200	-	3
160	120	200	-	3.2
200	120	200	-	3.5
250	120	200	30	4
315	120	200	60	4.9
400	210	290	60	8.4
500	210	290	110	10.3
630	210	290	180	13.4

d = Swedish Standard SS 2609 (spiral connection)

Actuator - damper sizes

Actuator BFL-T is supplied to damper sizes Ø100-315 mm.
Actuator BF-T is supplied to damper sizes Ø400-630 mm.

Electrical data (values in brackets refer to 230V)

	Actuator type BF..	BFL...
Sizing, max	10 VA (12.5 VA)	4 VA (6,5 VA)
Running time:		
- motor opening, max	approx. 120 s	60 s
- spring return, max	approx. 20 s	20 s (-10 to +55°C) 60 s (-30 to -10°C)
Protection class	IP 54	
Power supply	24V~ ±20%, 50/60Hz 24V= ±10% (220-240V~, 50/60Hz)	
Ambient temperature	-30° to +50°C	
Safety temperature	-30° to +75°C (24 hrs. guaranteed safety)	
Trigger temperature thermal sensor	72°C	
End position contacts		
- load ≤ 300 mW	min 1 mA/5V=, max 100 mA/250V~	
After exceeding the above values it applies:		
- load > 300 mW	min 100 mA, max 3 A/250~	
Sound level when opening	approx 45 dB(A)	
Sound level when closing	approx 62 dB(A)	

Wiring diagram RABC

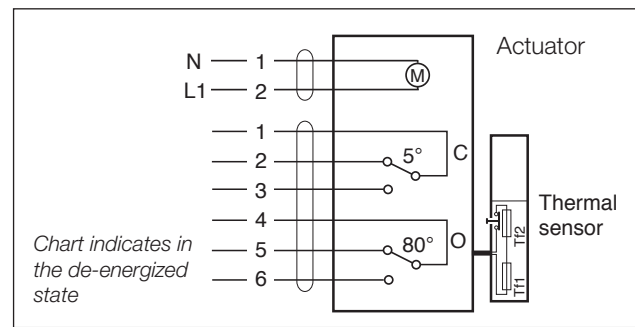

Connection to RCTU

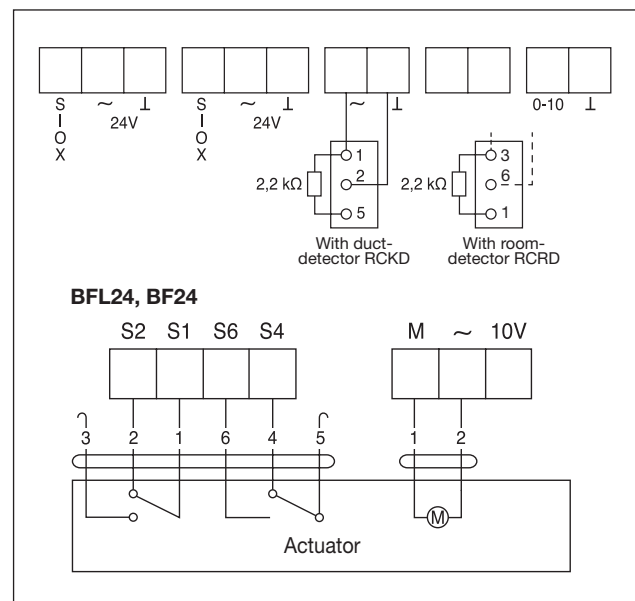



Size chart

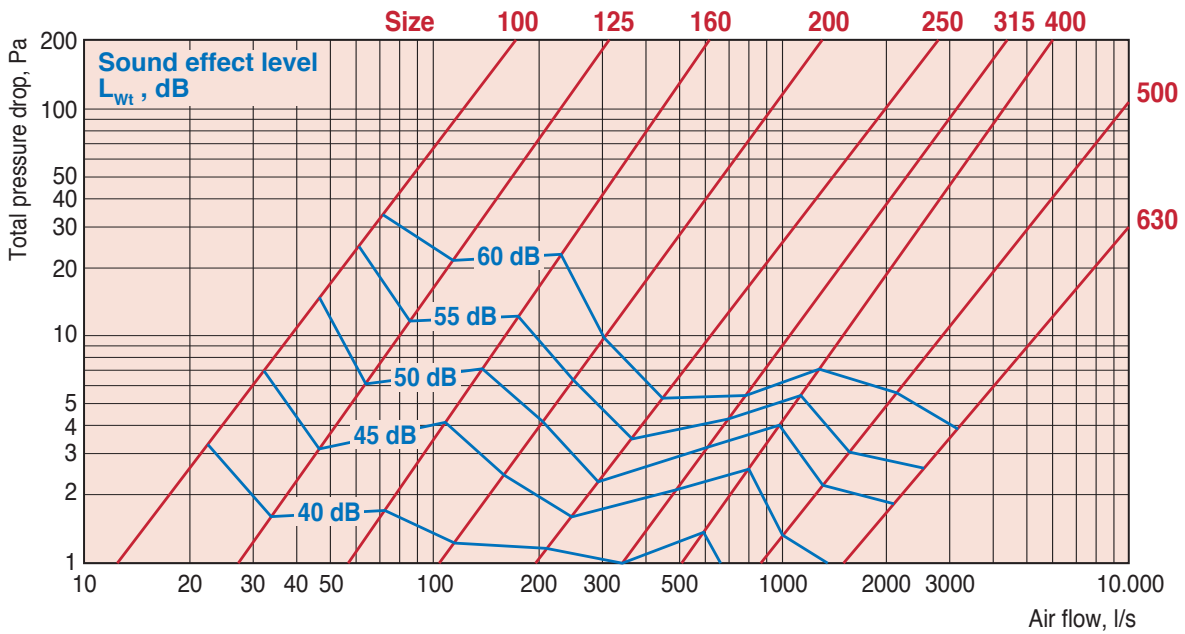

Sound data

Correction of sound power level, L_{wok}, in octave band

$$L_{w_{ok}} = L_w + K_{ok}$$

Correction, K_{ok}

Size Ø mm	Centre frequency Hz							
	63	125	250	500	1000	2000	4000	8000
100	-3	-7	-12	-19	-29	-27	-33	-32
125	-4	-5	-8	-13	-21	-25	-31	-35
160	-3	-4	-7	-13	-18	-22	-29	-37
200	-2	-8	-14	-20	-24	-28	-35	-41
250	-2	-9	-14	-19	-19	-28	-35	-42
315	-3	-8	-12	-12	-18	-24	-31	-35
400	-5	-7	-11	-6	-15	-22	-27	-28
500	-2	-10	-15	-13	-18	-24	-22	-31
630	0	-17	-3	-5	-10	-15	-22	-30
Tol. ± dB	2	4	5	7	10	10	9	7



Installation instruction

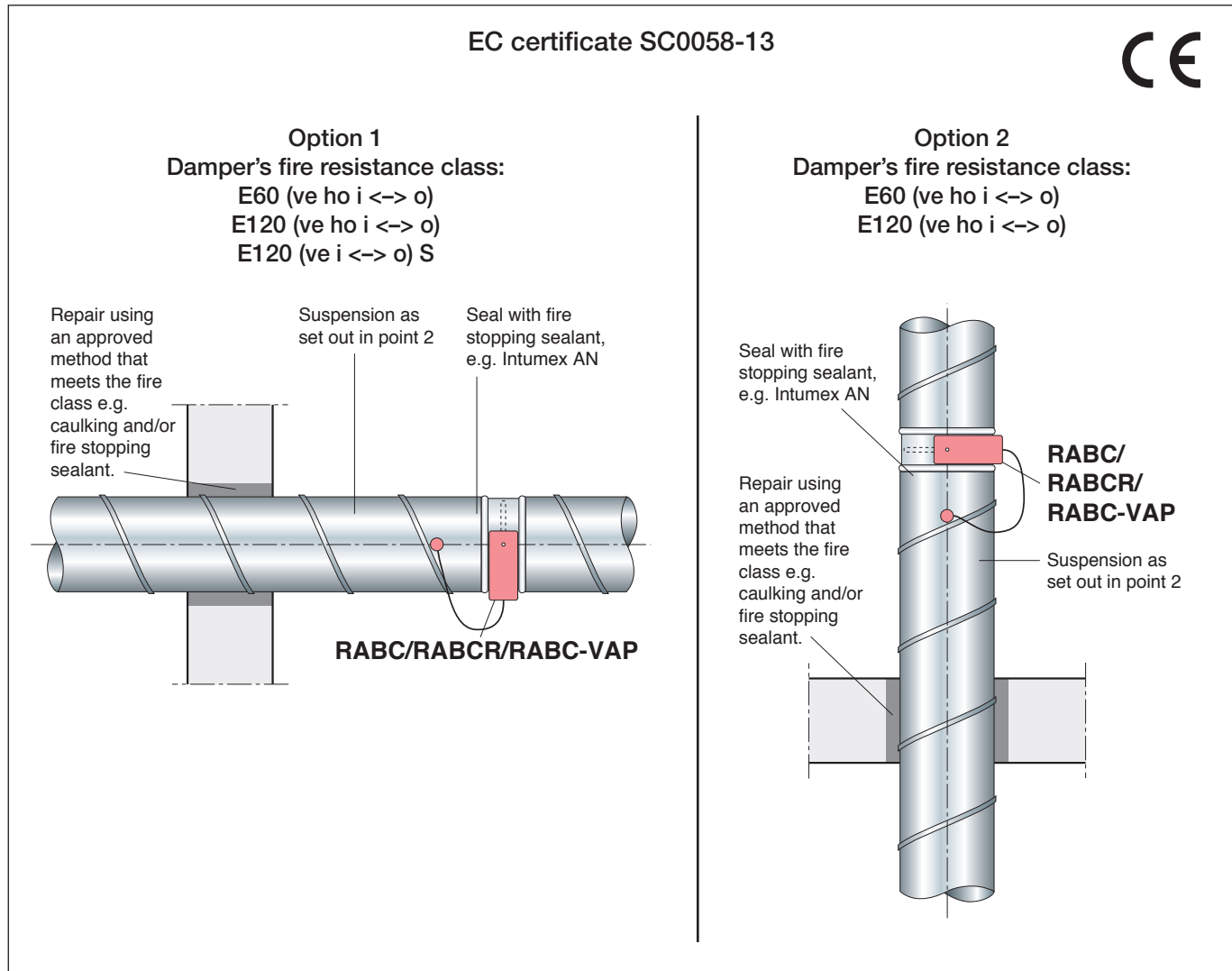

Options 1 and 2

1. Secure the damper in the duct and seal with fire stopping sealant, e.g. Intumex AN.
 2. Install the duct system according to applicable requirements. Between the damper and the penetrated building element the maximum spacing between hangers is 1500 mm. Use M10 drop rods and cradles or equivalent.
 3. Install the thermal sensor with the sensor body in the air stream without obstructing the movement of the damper blade.
- *Minimum distance between dampers must be 200 mm.*
 - *Minimum distance to joist structure/wall must be 75 mm.*
 - *No openings between dampers and fire separating building elements.*
 - *Optional installation of the damper spindle.*
 - *The damper can be installed in diagonal duct systems.*