

OPTIMUS 60[®]

Circular fire damper
EI60S



FIRE SAFETY

PATENT
PENDING



CE

20/06/2024



**PATENT
PENDING**



Quick facts

- Fire resistance class EI60S
- Sizes from 100 mm to 630 mm
- Adapted for reuse
- Installed without fire sealant and insulation strip
- No refinishing
- Easy installation from one side of the building element separating fire cells
- Available in MagiCAD

Use

Dampers in combination with walls or joists for fire-sectioning of heating, ventilation and air conditioning installations in buildings. In accordance with the European Standard EN 15650:2010. In designs according to associated documents, installation instructions and when the damper is used in combination with smoke detectors and monitoring system (FENIX, MRB, MRB3), or the like, the spread of fire/combustion gases is prevented. No further action against the spread of fire/combustion gases is required.

Performance

CoCP (Certificate of Constancy of Performance) EN 15650:2010
0402-CPR-C500380

Classification of fire resistance in accordance with EN 13501-3

EI60 (ve ho i <-> o) S

For complete classification, refer to the Performance Declaration.



Installation

OPTIMUS is mounted on a building element separating fire cells or in horizontal insulated ducts. Fit according to the enclosed installation instructions. Installation outdoors or in an exposed environment must take place in consultation with Bevent Rasch. Should not be installed outdoors or in damp areas.

Actuator

OPTIMUS is always supplied with an electric safety actuator with spring return complete with thermal sensor equipped with pushbutton for local manual operating test. The sensor breaks the power supply to the actuator device if the temperature exceeds 72°C inside or outside the damper. 24 V actuators are always used with FENIX, MRB3 and MRB monitoring systems. The damper can also be supplied with a 230 V electric actuator.

Activation

The Boverket Building Regulations state a requirement for smoke detectors verified in accordance with SS-EN 54-7 for activation of dampers. The obligatory thermal sensor closes the damper at 72 °C in accordance with ISO 10294-4.

Control and monitoring

When the damper is used to prevent the spread of fire and smoke, it must be closed via impulses from the smoke detector. The detector must be fitted in the ventilation duct near the damper or in another suitable location. Smoke detectors are monitored by means of Bevent Rasch's FENIX, MRB or MRB3 monitoring system. Monitoring systems from Bevent Rasch perform automatic function checks in accordance with current requirements. See www.bevent-rasch.com for further details.



Size Ø100-630 mm.

Design

OPTIMUS is supplied complete with a safety actuator. The actuator has position indication contacts and a thermal sensor. The damper has connections for a spiral folded duct as standard. The damper comes as standard with spiral duct connections.

Material and surface finish

- Casing and components of galvanised steel sheet according to environmental class C3
- EPDM duct seals
- Blade seal of PE/PP
- Blade of calcium silicate

Accessories

OPTIMUS-MS	Union piece
OPTIMUS-SK	Shaft ring
RCKD/-RD	Smoke detectors
RCTU/RCTC	MRB3-system, max 236 dampers
FENIX2	max 2 dampers
FENIX4 / FENIX+	max 16 dampers

Specification

Example:

Fire damper **OPTIMUS60 - 400 - 1 - 1**

Size, nom. diameter ØD mm

Material

Galvanised sheet steel = 1

Stainless EN 1.4016 = 3

Actuator

Electric 24 V with thermal sensor = 1

Electric 230 V with thermal sensor = 3

Electric 24 V incl. RCTU = 5

Note: Factory-fitted actuator device is always included.

Accessories specification

Example:

OPTIMUS-MS Union **OPTIMUS-MS - 400**

Size, nom. diameter ØD mm

Note: Required for installation in ducts, see installation instructions.

Example:

OPTIMUS-SK Shaft ring **OPTIMUS-SK - 400**

Size, nom. diameter ØD mm

Note: Required for installation in shaft walls, see installation instructions.

Installations options for OPTIMUS 60

Size	Fire class	Wall of drywall EI60 Group A, SS-EN1363-1	Solid wall	Solid floor*	Duct	Shaft wall
Ø100 - Ø630	EI60S	√	√	√	√	√

*125 mm lightweight concrete

Product data for OPTIMUS 60

Size	Pressure class	Casing tightness SS-EN1751	Tightness over damper blades SS-EN1751	Actuator type
Ø100 - Ø315	B	C	3**	Belimo BFL-T
Ø400 - Ø630	B	C	3	Belimo BFN-T

Pressure class B: 2500Pa

**Size Ø100-Ø125: 2



Dimensions and weight

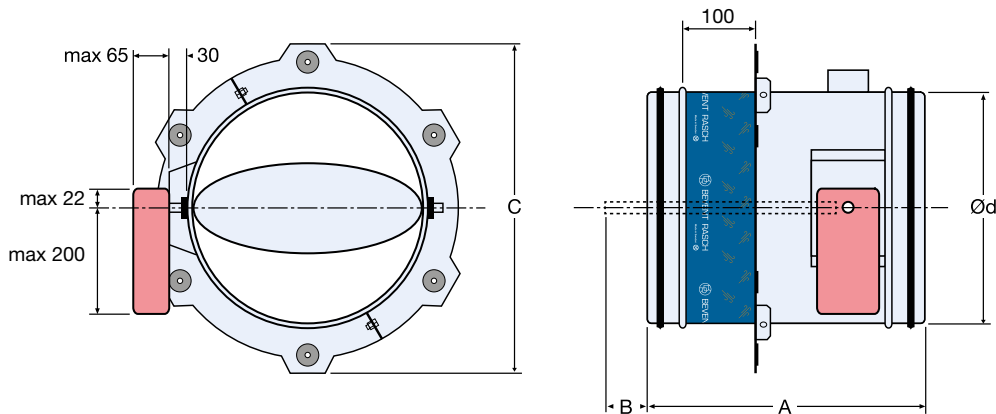

Size Ø mm	A	B	C	Weight, kg
100	375	-	237	2,6
125	375	-	262	2,9
160	375	-	295	3,3
200	375	-	335	3,8
250	375	21	385	4,5
315	375	84	450	5,5
400	477	95	534	9,7
500	477	145	634	12,7
630	477	210	764	16,6

OPTIMUS-MS Union piece

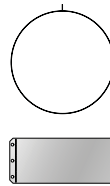

OPTIMUS-SK Shaft ring

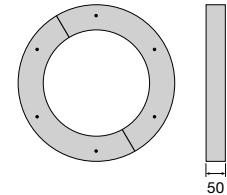

* If necessary, the actuator can be rotated 90°.

Actuator – damper size

Actuator BRL-T is supplied for dampers in size Ø100–315 mm.

Actuator BFN-T is supplied for dampers in size Ø400–630 mm.

Electrical data (values in brackets refer to 230 V)

Actuator type	BFL...	BFN...
Sizing, max	4 VA	6 VA
Running time;		
- motor opening, max	60 s	60 s
- spring return, max	approx. 20 s	20 s at -10 to +55°C < 60 s at -30 to -10°C
Protection class	IP 54 in all installation positions	
Supply voltage	24V~ ±20%, 50/60Hz 24V= ±10% (220-240V~, 50/60Hz)	
Design	I _{max} 8,3A @ 5ms	
Ambient temperature	-30° to +50°C	
Thermal sensor tripping temperature	72°C	
Mode contacts (Load)	1mA...3 (0,5 inductive) A, AC250V	
Sound level when opening	< 43 dB (A)	
Closing noise level	< 62 dB (A)	
Maintenance	Maintenance-free	

Wiring diagram

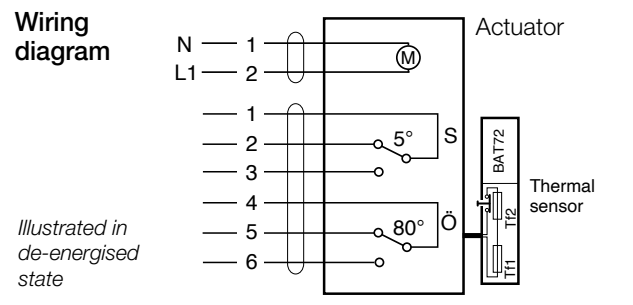

Illustrated in de-energised state



Dimensioning diagram

Size - 100

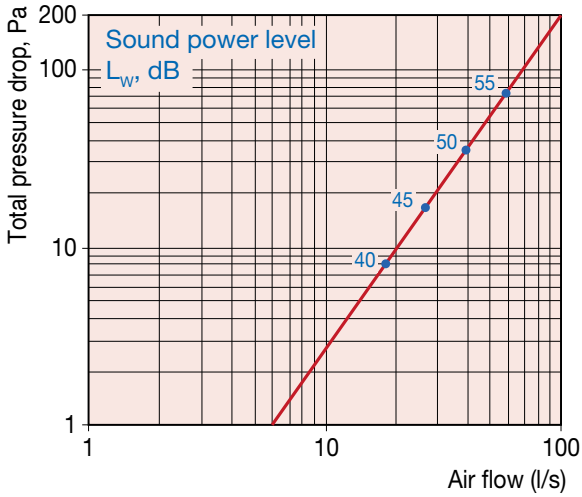

Size - 125

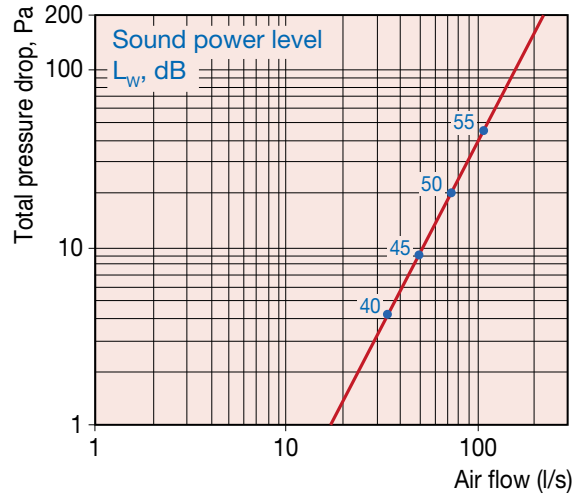

Size - 160

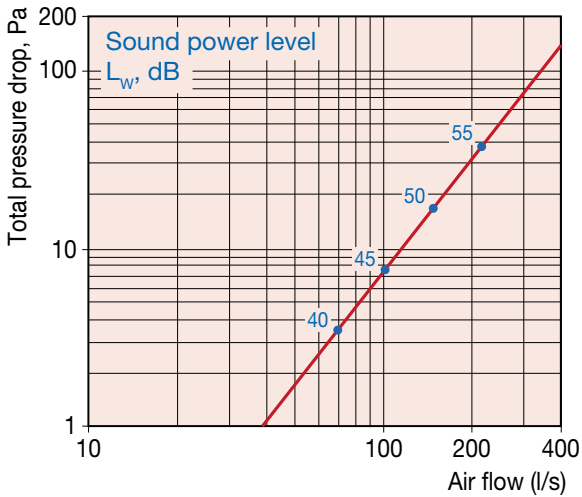

Size - 200

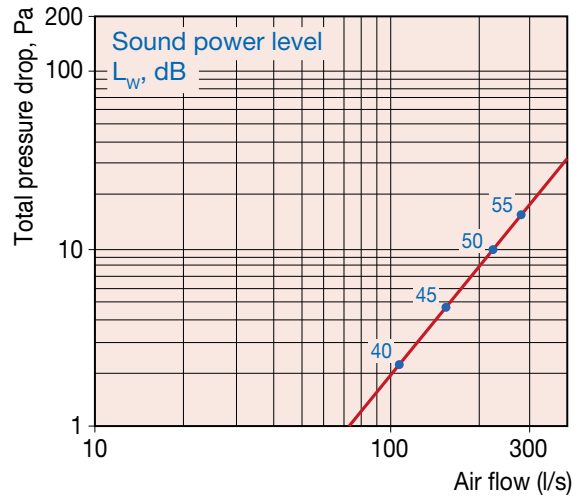

Size - 250

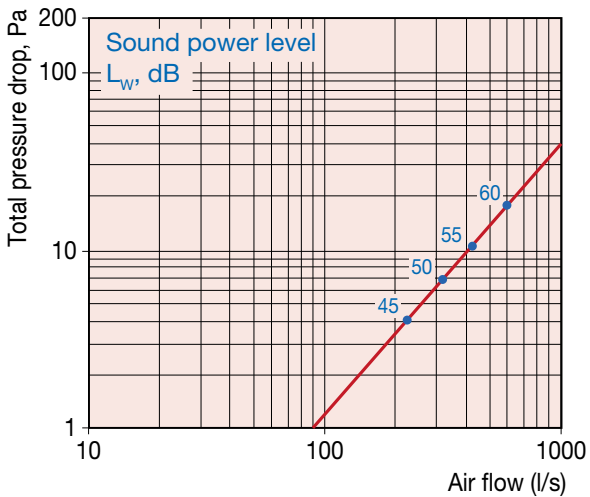

Size - 315

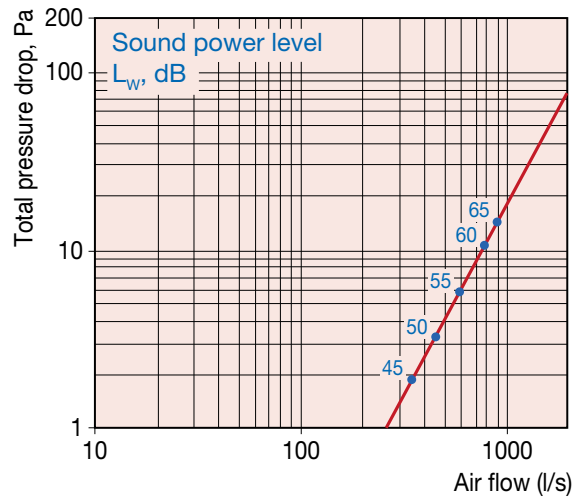



Size – 400

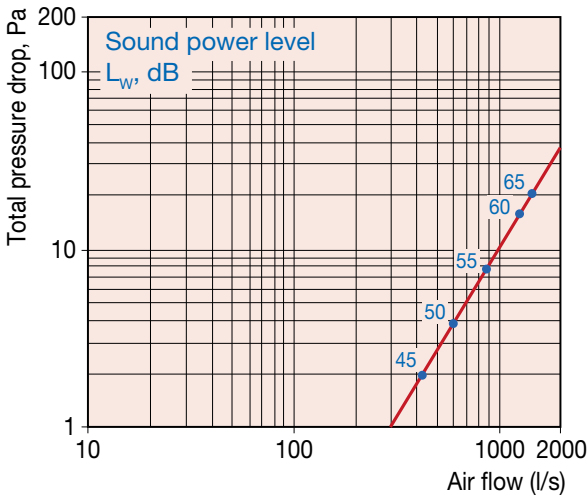

Size – 500

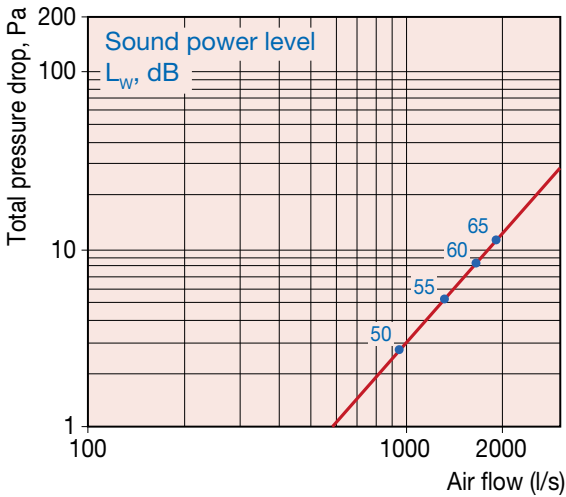

Size – 630

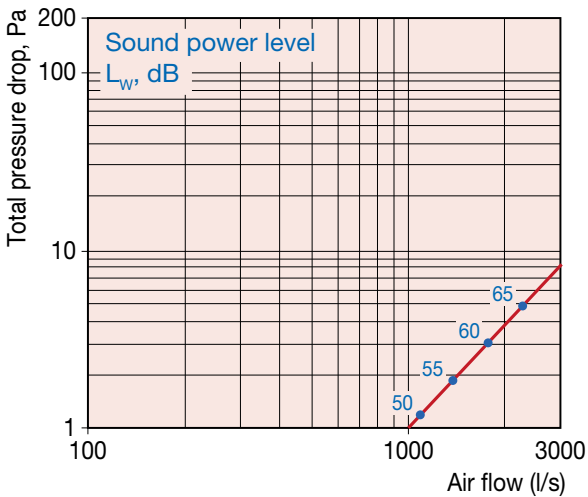

Sound data

Correction of sound power level, L_{wok}, in octave band

$$L_{wok} = L_w + K_{ok}$$

Correction, K_{ok}

Dimension Ø mm	Centre frequency Hz							
	63	125	250	500	1000	2000	4000	8000
100	-4	-9	-10	-10	-10	-15	-18	-22
125	-4	-8	-8	-9	-10	-15	-21	-22
160	-4	-7	-9	-11	-14	-16	-20	-25
200	-2	-8	-11	-14	-15	-18	-23	-25
250	-2	-11	-11	-14	-14	-21	-27	-28
315	-1	-12	-14	-16	-15	-23	-29	-29
400	-2	-10	-13	-15	-15	-21	-28	-29
500	-1	-11	-14	-17	-18	-24	-31	-32
630	-1	-11	-15	-17	-17	-25	-28	-31
Tol. ± dB	1	2	5	6	6	4	3	4



Installation instructions

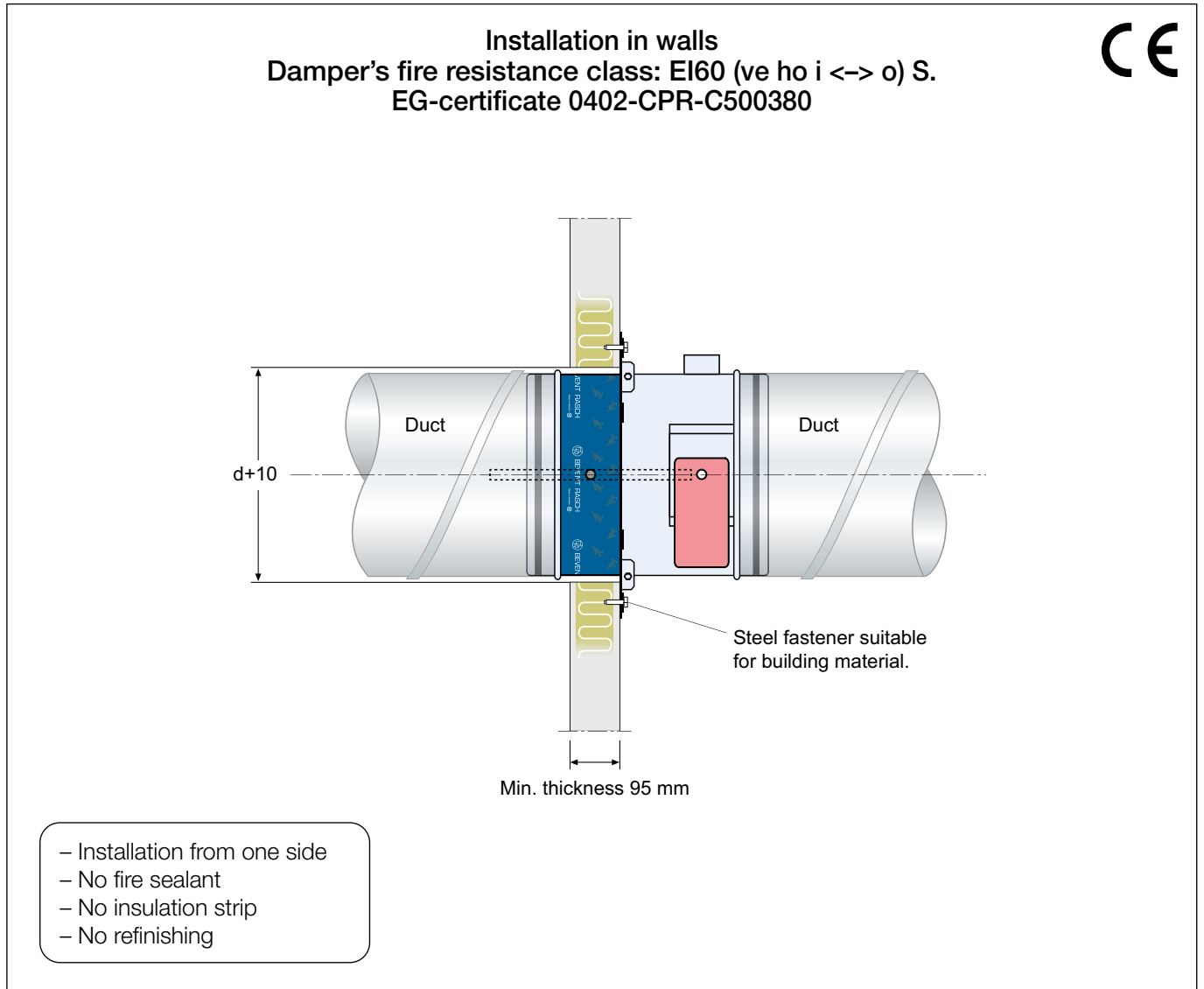

1. Make a hole for size in question ($d + 10$ mm).
2. Attach the damper to the duct and secure the mounting ring flat against the building element. Use the appropriate fastener for the building material in question. Make sure that the shape of the damper is not impacted during installation.
3. If necessary, the damper can be rotated after installation by loosening the screws in the mounting ring. Turn the damper to the desired position and lock the screws.
The actuator can be rotated to the desired position.
4. When installing without a duct connection, the damper should be fitted with an incombustible grille. Please note that from size $\text{Ø}250$ mm onwards the damper blade goes outside the casing in the open position.
5. The duct system is fitted in accordance with current requirements. Ensure that suspension and duct systems do not affect the movement of the damper blade.
 - Damper for installation in walls and floors.
 - The shortest distance between dampers must be 200 mm.
 - The minimum distance to the connecting structure should be 75 mm.
 - Free position on damper spindle.



Installation instructions

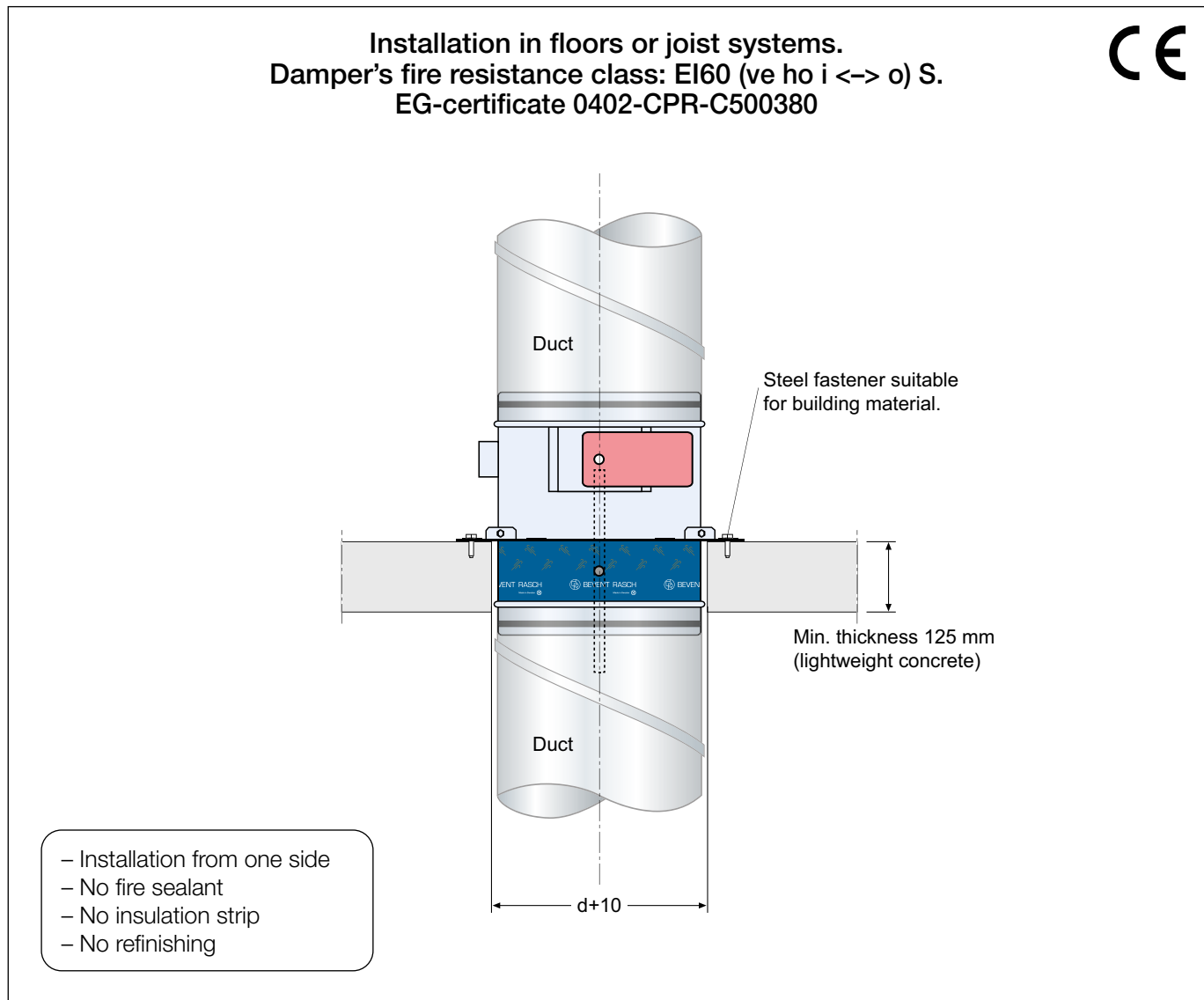

1. Make a hole for size in question (d + 10 mm).
2. Attach the damper to the duct and secure the mounting ring flat against the building element. Use the appropriate fastener for the building material in question. Make sure that the shape of the damper is not impacted during installation.
3. If necessary, the damper can be rotated after installation by loosening the screws in the mounting ring. Turn the damper to the desired position and lock the screws.
The actuator can be rotated to the desired position.
4. When installing without a duct connection, the damper should be fitted with an incombustible grille. Please note that from size Ø250 mm onwards the damper blade goes outside the casing in the open position.
5. The duct system is fitted in accordance with current requirements. Ensure that suspension and duct systems do not affect the movement of the damper blade.
 - Damper for installation in floors or joist systems.
 - The shortest distance between dampers must be 200 mm.
 - The minimum distance to the connecting structure should be 75 mm.



Installation instructions

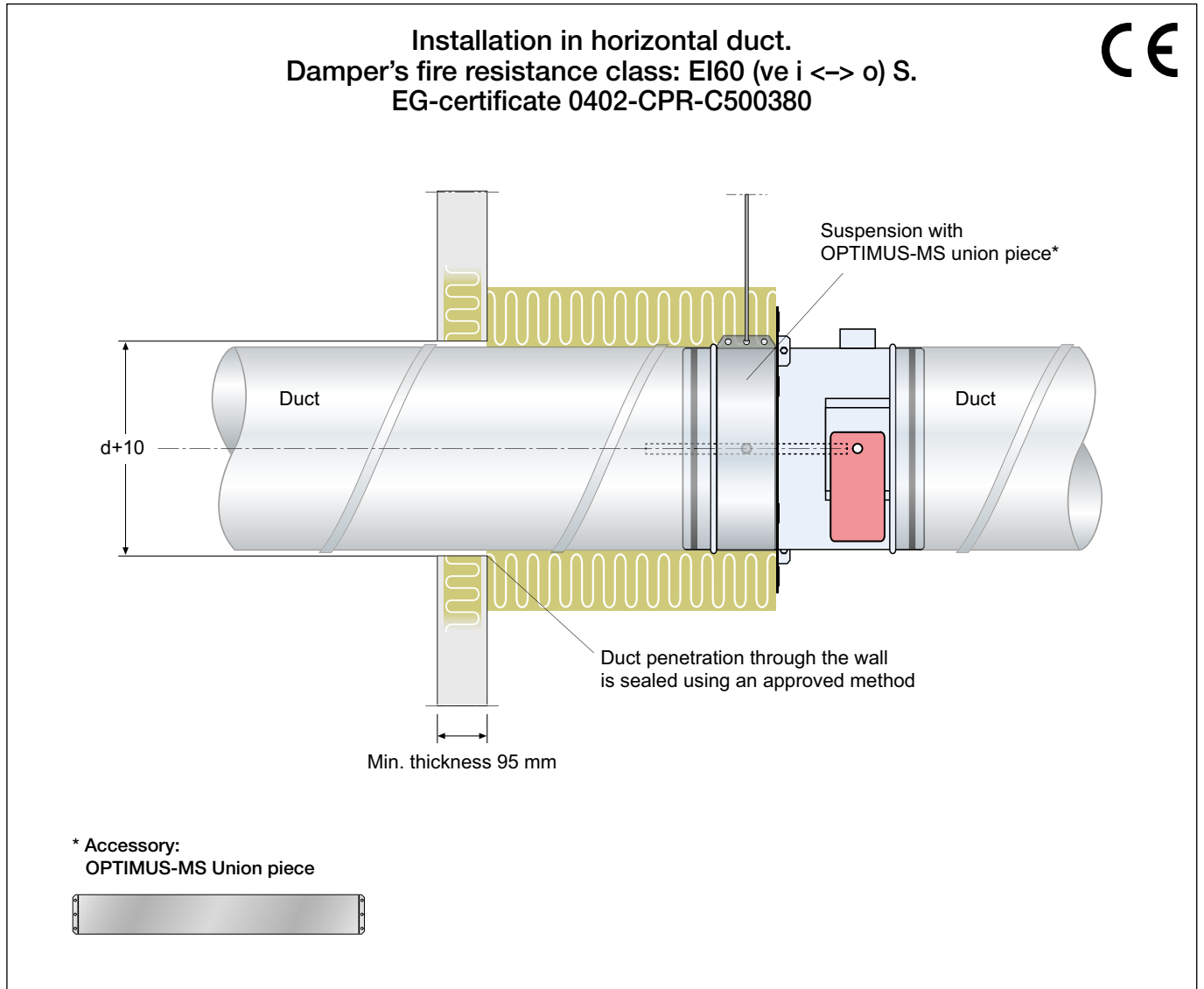

1. Make a hole for size in question ($d + 10$ mm).
 2. Seal the wall penetration according to the circular ventilation duct method.
 3. Install the OPTIMUS-MS union piece accessory over the decal on the damper casing.
 4. When installing without a duct connection, the damper should be fitted with an incombustible grille.
 5. Insulate the duct from the wall penetration up to the damper's mounting ring. Insulate the EI60 duct system according to the supplier's instructions.
 6. The duct system is fitted in accordance with current requirements. Ensure that suspensions and duct systems do not affect the shape of the damper or impede the movement of the damper blade.
- Damper for installation in horizontal duct systems.
 - The shortest distance between dampers must be 200 mm.
 - The minimum distance to the connecting structure should be 75 mm.
 - Free position on damper spindle.



Installation instructions

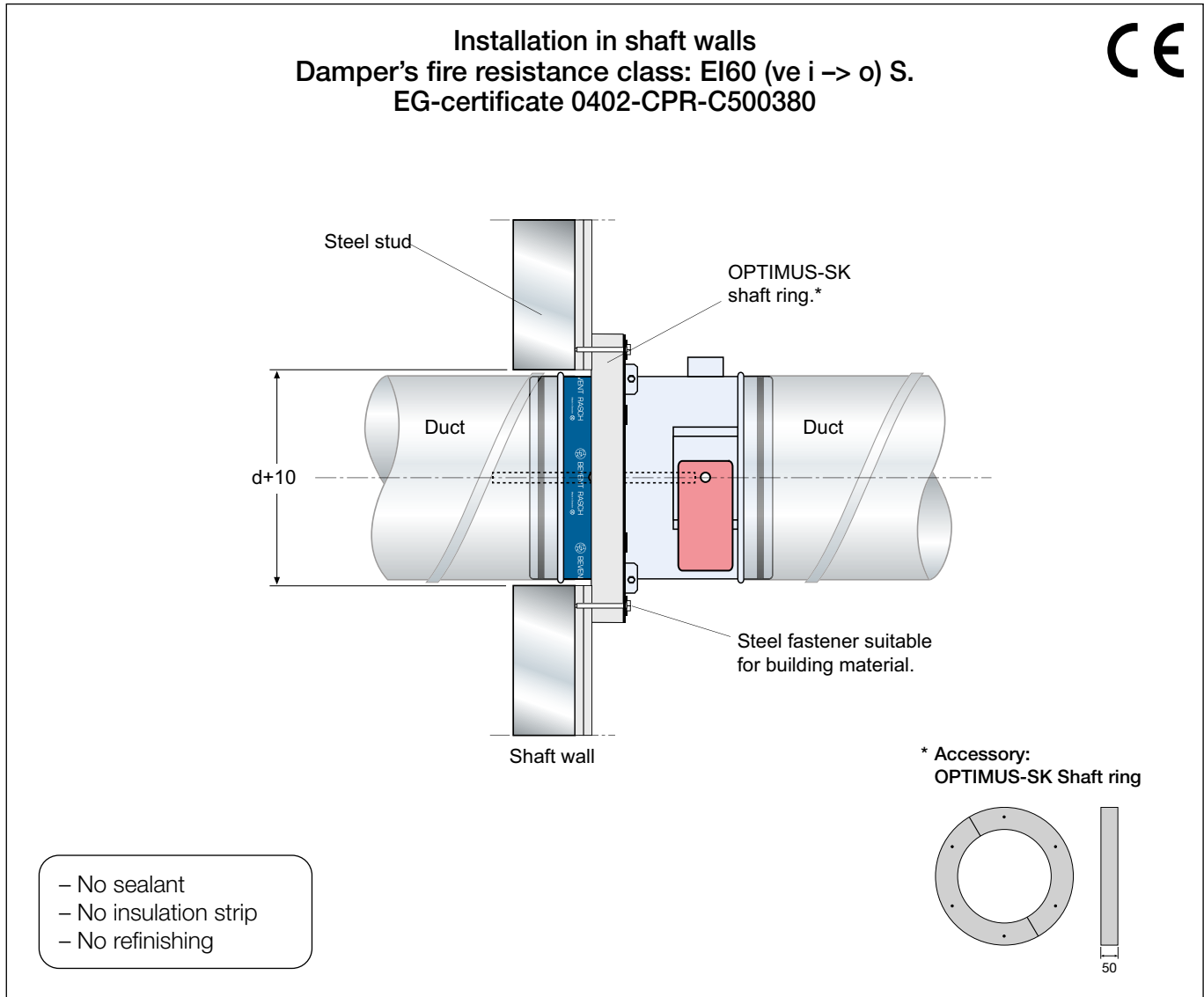

1. Make a hole for size in question (d + 10 mm).
2. Install the OPTIMUS-SK shaft ring accessory between the damper's mounting ring and the wall. Secure the damper with an appropriate fastener for the building material in question. Make sure that the shape of the damper is not impacted during installation.
3. If necessary, the damper can be rotated after installation by loosening the screws in the mounting ring. Turn the damper to the desired position and lock the screws. The actuator can be rotated to the desired position.
4. When installing without a duct connection, the damper should be fitted with an incombustible grille.
5. The duct system is fitted in accordance with current requirements. Ensure that suspension and duct systems do not affect the movement of the damper blade.

- Damper for installation in shaft walls.
- The shortest distance between dampers must be 200 mm.
- The minimum distance to the connecting structure should be 75 mm.
- Free position on damper spindle.