

DELTA-DU

Intake Air Cowl

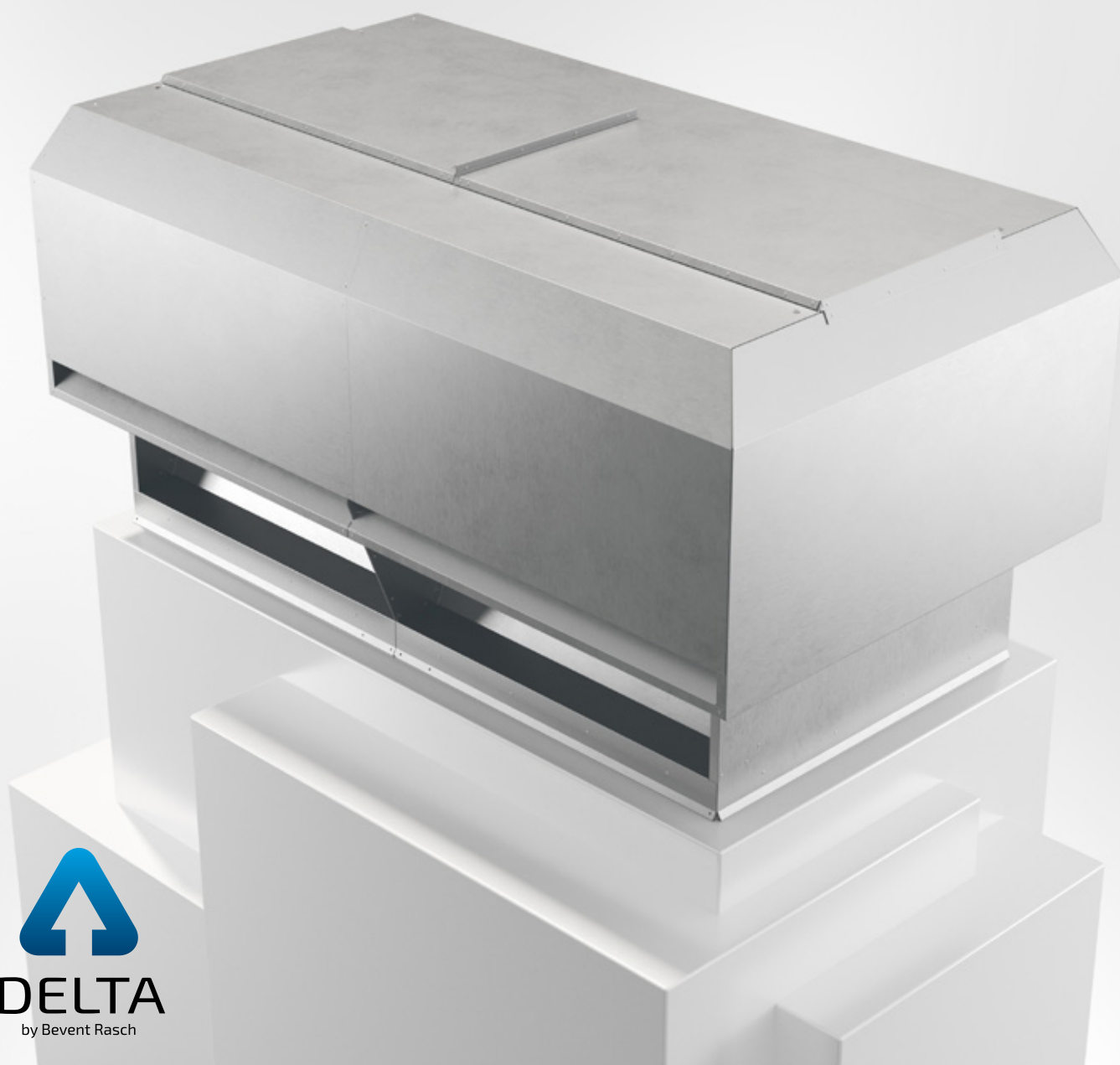

COWLS



19/08/2024



Intake Air Cowl DELTA-DU



This cowl design is also available as Intake Air Cowl DELTA-UH, Exhaust Air Cowl DELTA-AH and Combination Cowl DELTA-KH.

Quick facts

- Sizes for flows from 200 l/s to 30,000 l/s
- Design similar to Intake Air Cowl DELTA-UH, Exhaust Air Cowl DELTA-AH and Combination Cowl DELTA-KH
- Fully rain protected intake
- Integrated lifting points
- Fits roof inlets BRTF and BRTK

Use

DELTA-DU is a double intake cowl for use with comfort and industrial air-conditioning units. The outdoor air is taken in on the lower edge of the cowl. The intake opening is covered with bird/rodent-proof netting. DELTA-DU is supplied as standard with integrated lifting points to facilitate installation. DELTA-DU is ideally installed on our roof inlet BRTF or BRTK if penetrating the outer roof. Supplied with integrated lifting points.

Material, surface finish

The air cowl is manufactured as standard in Magnelis, corrosivity class C4 and can be supplied in the desired colour, see www.bevent-rasch.com. The air cowl can also be supplied in stainless steel AISI 316L (EN 1.4404).

Specification

Examples:

Intake Air Cowl **DELTA-DU - 300 - 5 - 0**

Size, refer to dimension table

Material:

Magnelis ZM120 C4 = 5

Stainless AISI 316L – EN 1.4404 = 3

Surface treatment:

Untreated C3 = 0

Surface treatment C4 = 1*

* Colour code stated in plain text, see www.bevent-rasch.com

Accessories:

Roof inlet BRTF, see www.bevent-rasch.com

Roof inlet BRTK, see www.bevent-rasch.com

Special

The air cowls can be supplied in many different custom designs in terms of dimensions, choice of material, etc. CFD-simulation can also be performed for custom designs. Contact Bevent Rasch.



Selection chart

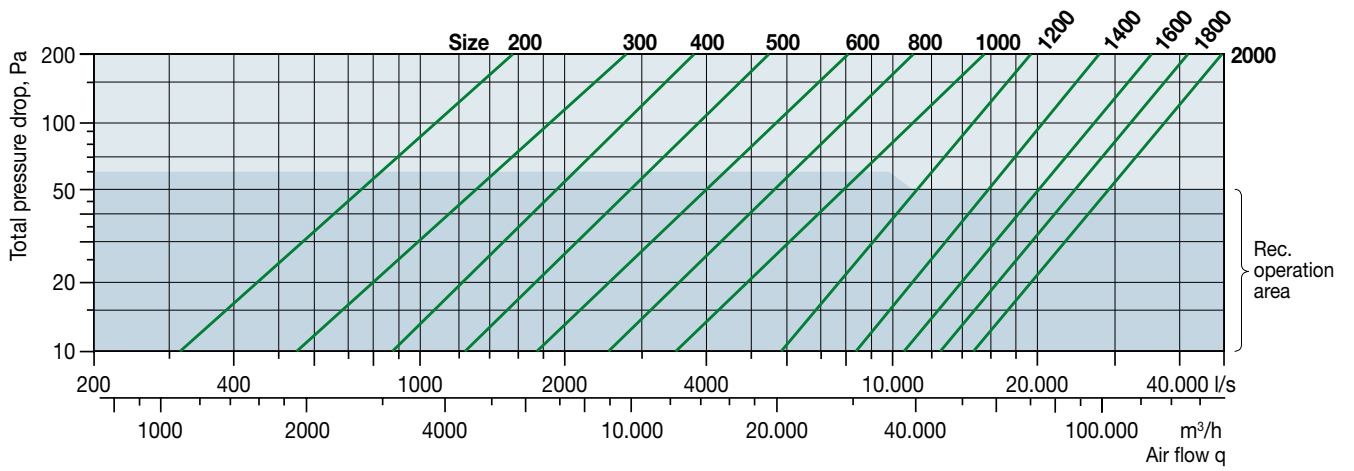

Dimensions

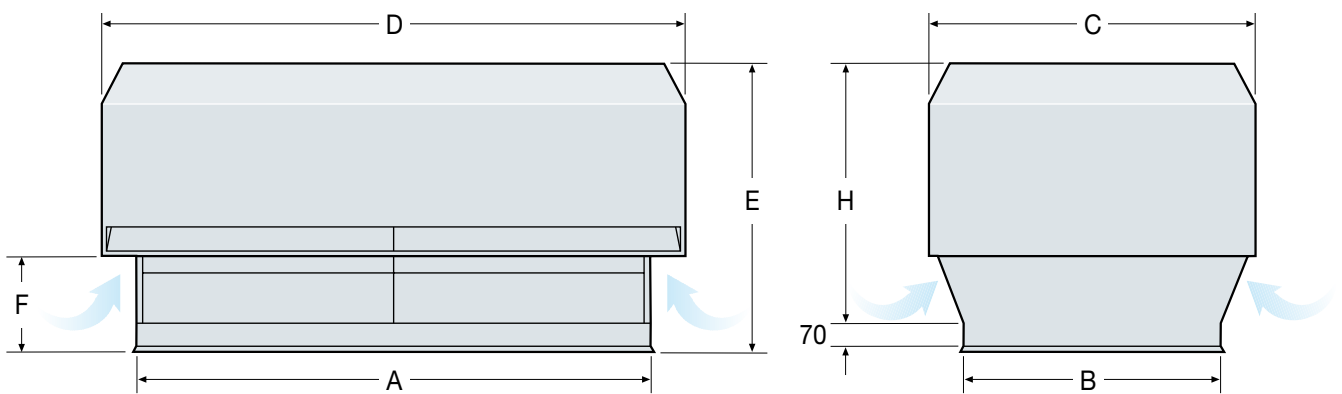

Size	A	B	C	D	E	F	H	Fits BRTF/BRTK	Weight kg
200	800	400	510	910	505	195	405	200	26
300	1000	500	635	1135	605	220	505	300	38
400	1200	600	760	1365	710	245	610	400	54
500	1400	700	890	1590	810	270	710	500	70
600	1600	800	1015	1820	910	300	810	600	90
800	2000	1000	1270	2270	1110	350	1010	800	138
1000	2400	1200	1530	2725	1315	405	1215	1000	190
1200	2800	1400	1780	3180	1520	455	1420	1200	282
1400	3200	1600	2035	3635	1720	510	1620	1400	362
1600	3600	1800	2290	4085	1920	560	1820	1600	450
1800	4000	2000	2545	4540	2125	610	2025	1800	548
2000	4400	2200	2800	4995	2325	665	2225	2000	656