

# OPTIMUS 60-VAP®

Circular fire damper with constant pressure retention function



FIRE SAFETY

PATENT  
PENDING



CE  
UK  
CA

30/09/2024



## Quick facts

- Fire resistance class EI60/EI60S
- Sizes from 100 mm to 630 mm
- Fitted modulating safety actuator 24V
- Simple pressure regulation, VAP/CAP
- Modbus communication
- CE-marked building product in acc. with EN 15650:2010

## Two dampers in one!

Bevent Rasch has developed a fire damper with a fire class EI60/EI60S rating that is also used for pressure regulation in all types of ventilation plants while providing comprehensive protection against the spread of combustion gases.

## Use

Dampers in combination with walls or joists for fire-sectioning of heating, ventilation and air conditioning installations in buildings. In accordance with the harmonised European Standard EN 15650:2010. When implemented as per the associated documents and installation instructions, and when the damper is used in combination with smoke detectors and an MRB3 or FENIX monitoring system, the spread of fire/combustion gases is prevented. No further action against the spread of fire/combustion gases is required. Since the damper has a pressure regulation function, both functions are combined in a single damper. This saves time, space and money for installations in, say, hotels or office and shopping complexes where both of these functions are required.

## Performance

CoCP (Certificate of Constancy of Performance) and UKCA certificate according to EN 15650:2010  
**0402-CPR-C500380**  
**2822-UKCA-CPR-0135**

Classification of fire resistance in accordance with EN 13501-3

**EI60 (ve ho i <-> o) S**

For complete classification, refer to the Performance Declaration.



## Installation

OPTIMUS 60-VAP is installed where ducts penetrate building elements as per the supplied installation instructions. If installed as a termination device, the damper must be fitted with steel meshing.

Should not be installed outdoors or in damp areas.

## Actuator

OPTIMUS 60-VAP is always supplied with an electric safety actuator with spring return complete with thermal sensor equipped with pushbutton for local manual function test. The sensor breaks the power supply to the actuator if the temperature exceeds 72°C inside or outside the damper. 24 V actuators are always used with MRB3 and FENIX monitoring systems. Note that the damper is always supplied with a safety actuator.

## Activation

The Boverket Building Regulations regulations state a requirement for smoke detectors verified in accordance with SS-EN 54-7 for activation of dampers. The obligatory thermal sensor closes the damper at 72°C in accordance with ISO 10294-4.

## Control and monitoring

When the damper is used to prevent the spread of fire and combustion gases, it must be closed via impulses from the smoke detector or thermal sensor. The thermal sensor must be fitted in the ventilation duct near the damper or in another suitable location. Smoke detectors are monitored using a Bevent Rasch MRB3 or FENIX control unit. The control unit performs automatic function tests on the damper every 48 hours and is designed so that faults are indicated immediately and the damper closes, which is a requirement of the P certificate.

For further information, refer to the technical section on the website.

The following Bevent Rasch monitoring units can be used:

- MRB3 with RCTC/RCTU
- FENIX with 0–10 V unit

## Size

Ø100 – 630 mm.



### Design

OPTIMUS 60-VAP is supplied complete with a factory mounted, maintenance-free, 24 V electric safety actuator with thermal sensor featuring built-in signal contacts to indicate the damper position. OPTIMUS 60-VAP is supplied ready for 50 mm of additional insulation, if required. The pressure regulator offers six different pressure ranges: from 0 to 100, 300, 500, 700, 1000 and 2000 Pa. The CAP (constant air pressure) or VAP (variable air pressure) function is selected via the pressure regulator. With CAP control, a desired setpoint is defined within the selected pressure range, while with VAP control, the pressure is regulated between set min and max pressures with an analogue 0/2–10 V signal or via modbus. The actuator can be force-controlled to different operational requirements via two digital inputs or modbus. In the event of a power failure, the damper is closed by the actuator's spring.

### Material and surface finish

- Casing and details of galvanized steel sheet according of environmental class C3
- EPDM duct seals
- Blade seal of PE/PP
- Blade of calcium silicate

### Accessories

- OPTIMUS-MS** Union piece
- OPTIMUS-SK** Shaft ring
- RCKD/-RD** Smoke detectors
- RCTU/RCTC** MRB3-system, max 236 dampers
- FENIX2** max 2 dampers
- FENIX4 / FENIX+** max 16 dampers

### Specification

Example: **Fire damper**  
**OPTIMUS60-VAP - 400 - 1 - 0**

*Size*  
Nom. diameter Ød, mm \_\_\_\_\_

*Material*  
Galvanised sheet steel = 1  
Stainless EN 1.4016 = 3

*MRB3 unit*  
Without MRB3 unit = 0  
With MRB3 unit fitted (RCTU) = 5

*Note: Factory-fitted actuator always included.*

### Specification Accessories

Example:  
**OPTIMUS-MS Union piece** **OPTIMUS-MS - 400**

*Size, nom. diameter ØD mm* \_\_\_\_\_

*Note: Required for installation in ducts, see installation instructions.*

Example:  
**OPTIMUS-SK Shaft piece** **OPTIMUS-SK - 400**

*Size, nom. diameter ØD mm* \_\_\_\_\_

*Note: Required for installation in shaft walls, see installation instructions.*

### Installation options for OPTIMUS 60-VAP

Size	Fire class	Wall of drywall EI60 Group A, SS-EN1363-1	Solid wall	Solid floor*	Duct	Shaft wall
Ø100 - Ø630	EI60S	√	√	√	√	√

\*125 mm lightweight concrete

### Product data for OPTIMUS 60-VAP

Size	Pressure class	Casing tightness SS-EN1751	Tightness over damper blades SS-EN1751	Actuator type
Ø100 - Ø315	B	C	3**	Belimo BFL-SR-T
Ø400 - Ø630	B	C	3	Belimo BFN-SR-T

Pressure class B: 2500Pa

\*\*Size Ø100-Ø125: 2



### Dimensions and weight

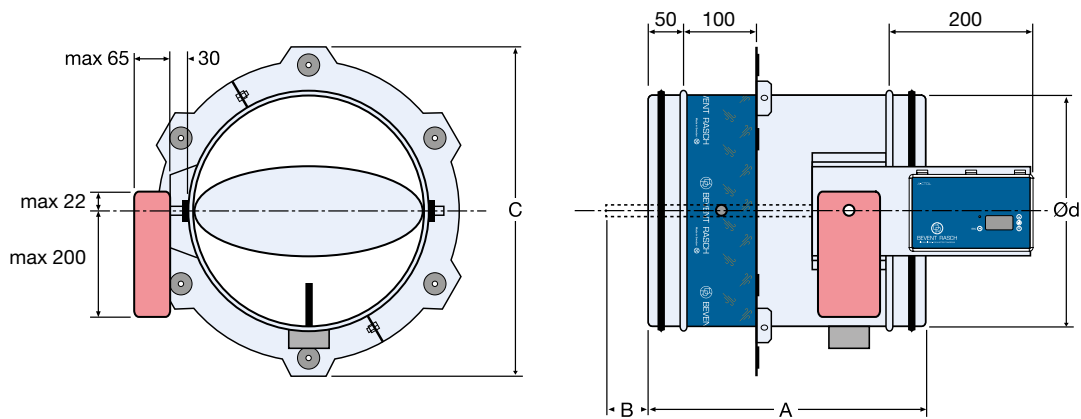

Size Ø mm	A	B	C	Weight, kg
100	375	-	237	3,3
125	375	-	262	3,6
160	375	-	295	4,0
200	375	-	335	4,5
250	375	21	385	5,2
315	375	84	450	6,2
400	477	95	534	10,4
500	477	145	634	13,4
630	477	210	764	17,3

OPTIMUS-MS Union piece

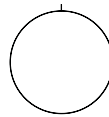

OPTIMUS-SK Shaft ring

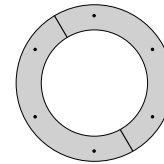

\* If necessary, the actuator can be rotated 90°.

### Actuator - damper size

Actuator BFL24-SR-T is supplied for damper sizes Ø100-400 mm.

Actuator BFN24-SR-T is supplied for damper sizes Ø500-630 mm.

### Electrical data

Actuator type	BFL24-SR-T	BFN24-SR-T	A-CTRL (regulator)
Dimensioning, max	6,5 VA	8,5 VA	2,6 VA
Running time; - motor opening, max - spring return, max	60 s 20 s at -10 to +55°C 60 s at -30 to -10°C	60 s 20 s at -10 to +55°C < 60 s at -30 to -10°C	
Protection class	IP 54 in all installation positions		
Supply voltage	24V~ ±20%, 50/60Hz 24V= ±10%, 50/60Hz		
Control signal			DC 0/2-10V modbus
Measurement signal			DC 0/2-10V modbus
Position reversal	2-10V		modbus
Dimensioning	I <sub>max</sub> 8,3A @ 5ms		
Ambient temperature	-30° to +50°C		-20° to +50°C
Thermal sensor tripping temperature	72°C		
Position contacts (Load)	1mA...3 (0,5 A inductive) DC 5V...AC250V	1mA...3 (0,5 inductive) A, AC250V	
Sound level when opening	43 dB (A)	< 55 dB (A)	
Sound level when closing	62 dB (A)	< 67 dB (A)	
Maintenance	Maintenance free		



Dimensioning diagram

Size - 100

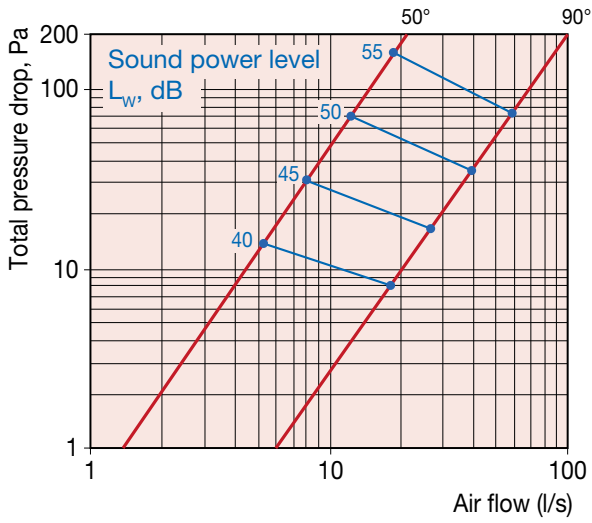

Size - 125

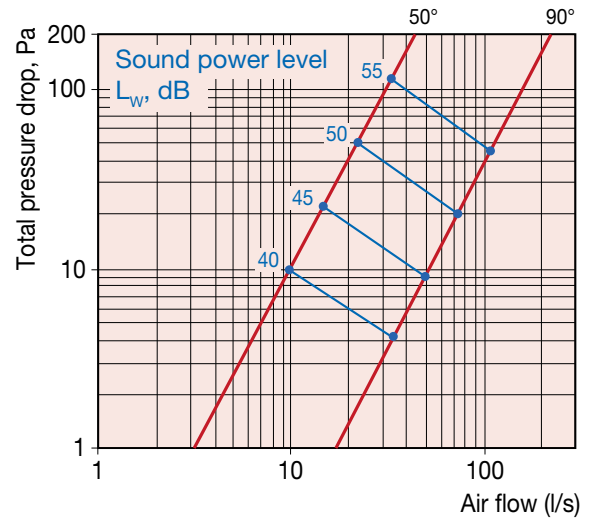

Size - 160

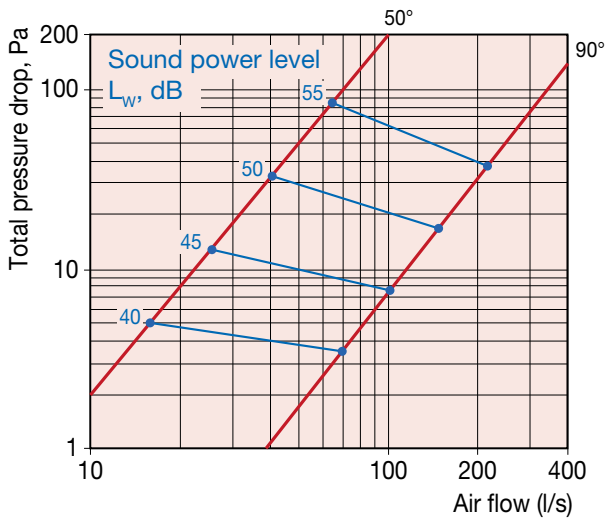

Size - 200

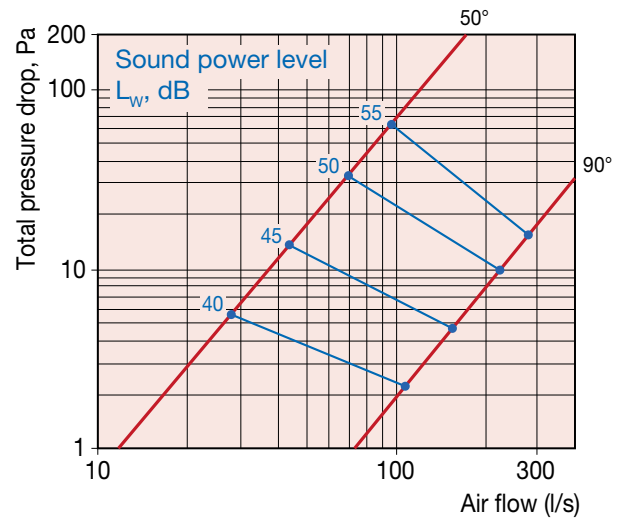

Size - 250

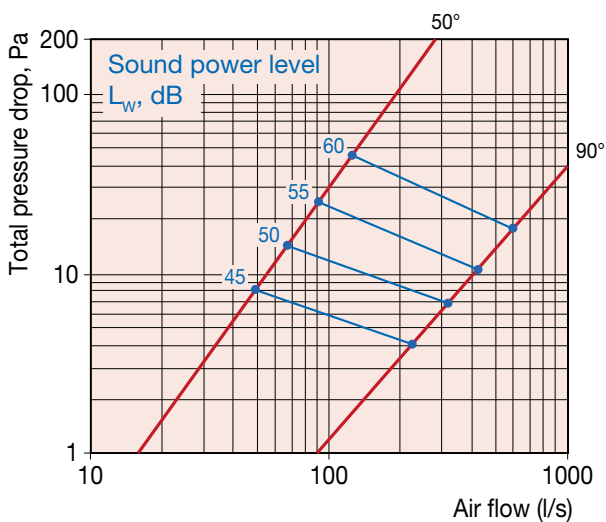

Size - 315

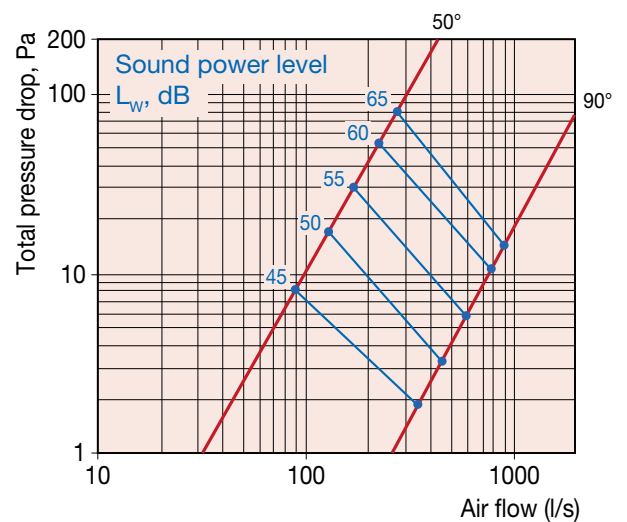



**Dimensioning diagram contd.**

**Size - 400**

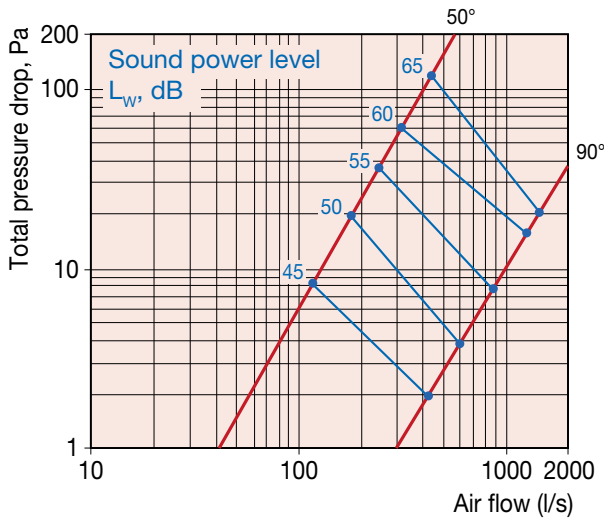

**Size - 500**

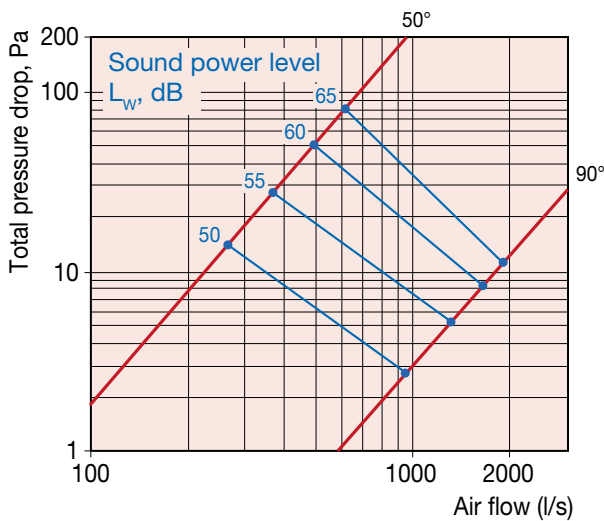

**Size - 630**

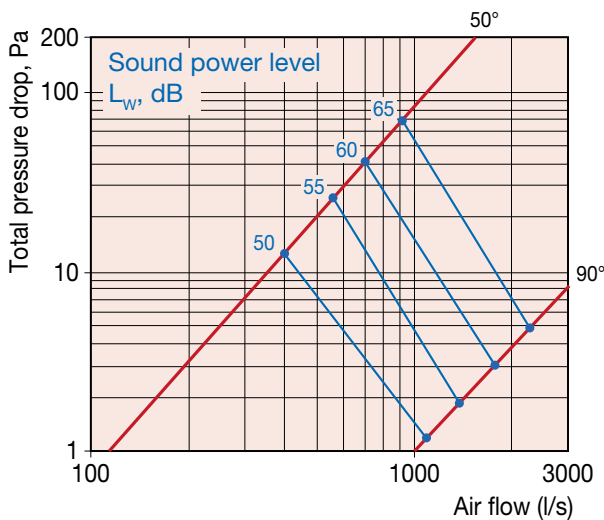

**Sound data**

Correction of sound power level,  $L_{Wok}$ , in octave band

$$L_{Wok} = L_{Wt} + K_{ok}$$

Correction,  $K_{ok}$

Size Ø mm	Centre Frequency Hz							
	63	125	250	500	1000	2000	4000	8000
100	-4	-6	-7	-12	-17	-24	-26	-33
125	-5	-5	-8	-14	-22	-25	-27	-35
160	-5	-4	-8	-13	-17	-20	-28	-34
200	-3	-6	-10	-14	-15	-19	-27	-40
250	-1	-11	-15	-20	-22	-23	-29	-37
315	-2	-8	-11	-12	-13	-19	-23	-29
400	-2	-8	-14	-12	-15	-22	-30	-41
500	-2	-8	-13	-13	-15	-21	-28	-36
630	0	-15	-23	-23	-28	-35	-41	-48
Tol. ± dB	2	3	4	4	6	7	9	9

**Installation**

The pressure sensor is mounted in an appropriate position in the duct with the arrow in the direction of the airflow. The measurement hose must be attached to the duct and the pressure sensor on the damper. If the damper is mounted in an exhaust air duct, the measurement hose must be moved to the negative nipple of the static pressure sensor.

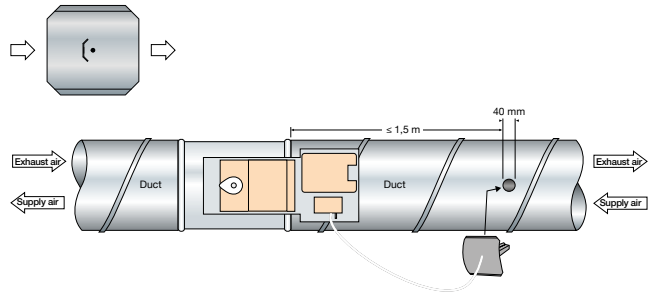



Wiring diagram

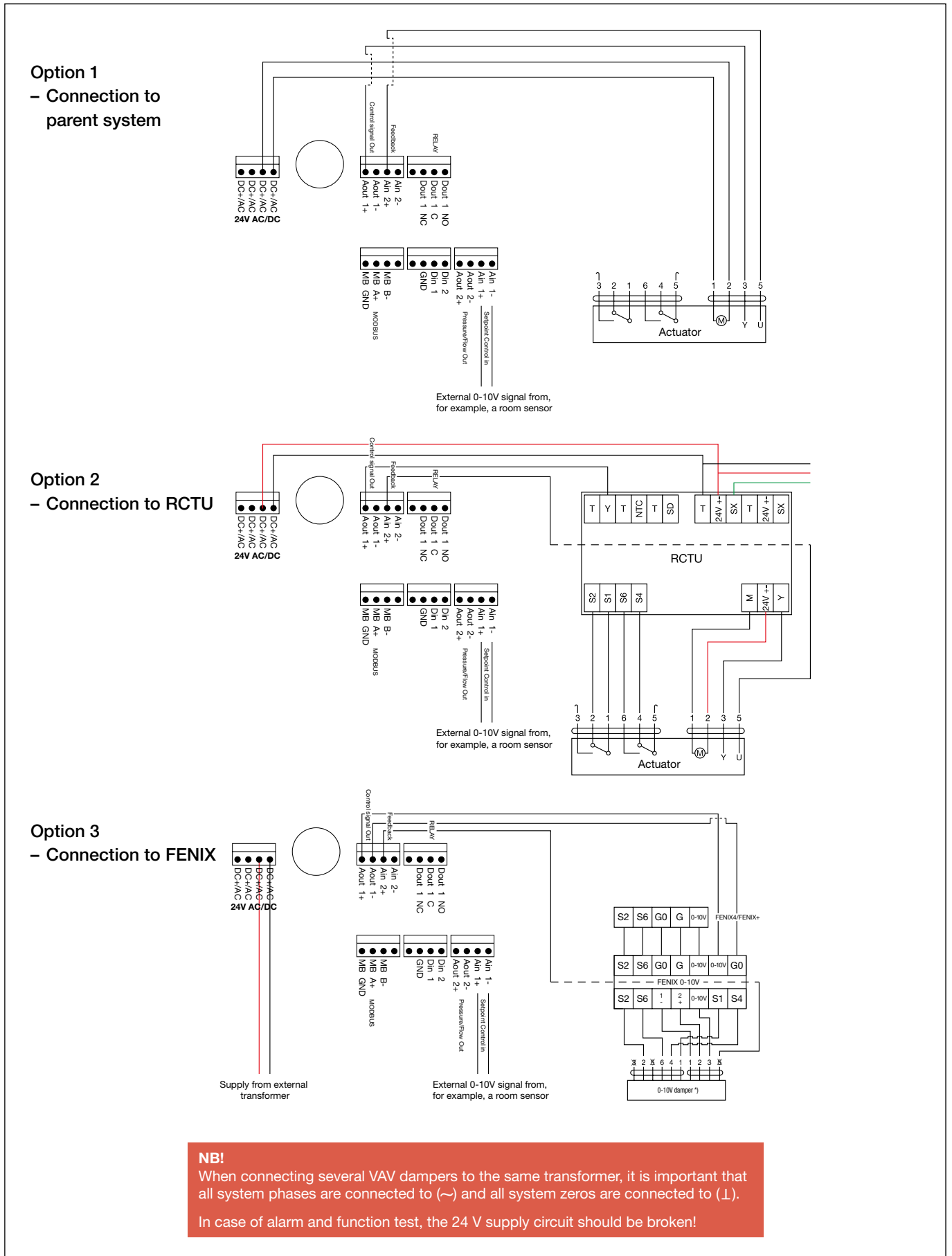



## Installation instruction

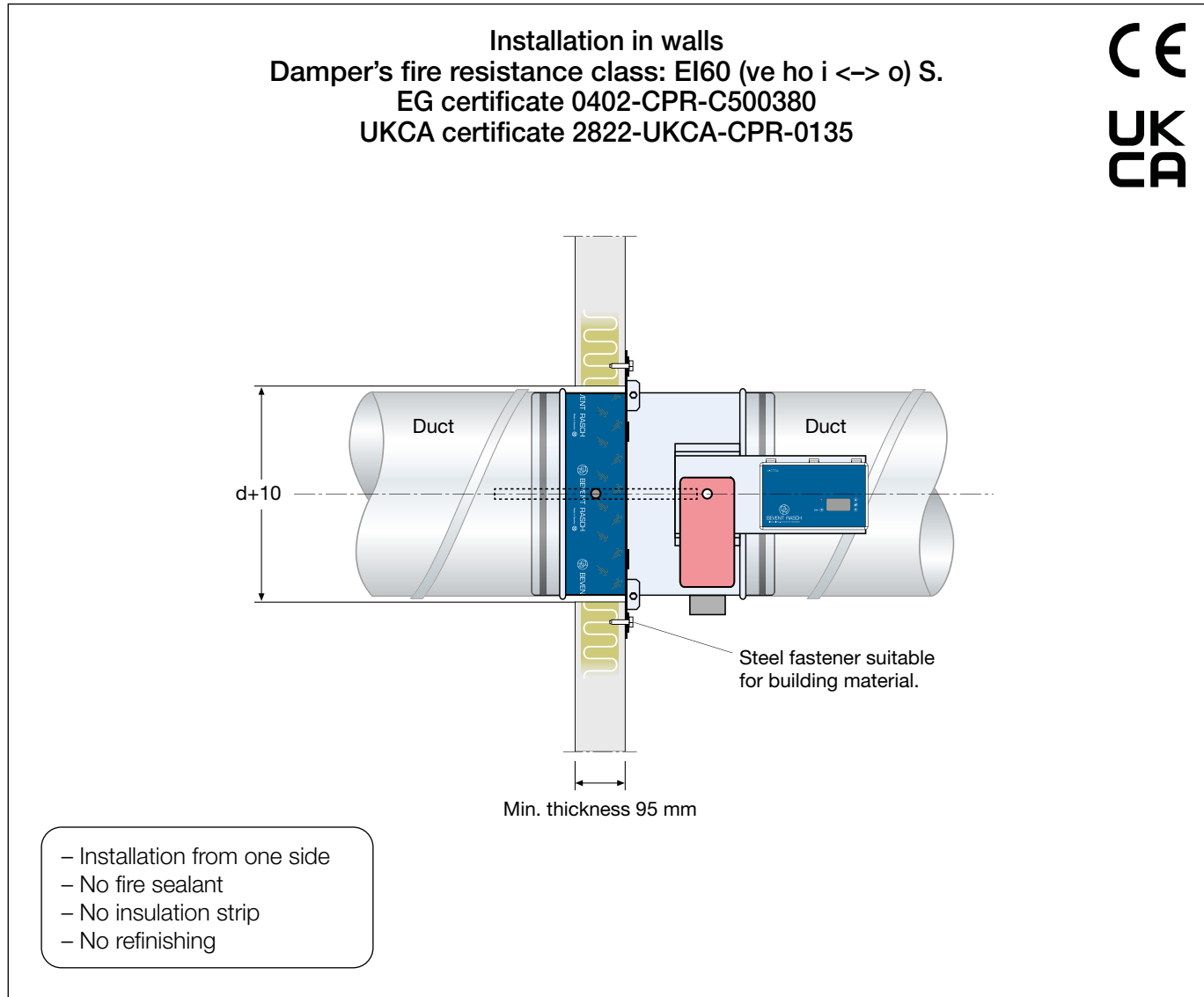

1. Make a hole for size in question ( $d + 10$  mm).
2. Attach the damper to the duct and secure the mounting ring flat against the building element. Use the appropriate fastener for the building material in question. Make sure that the shape of the damper is not impacted during installation.
3. If necessary, the damper can be rotated after installation by loosening the screws in the mounting ring. Turn the damper to the desired position and lock the screws.  
The actuator can be rotated to the desired position.
4. When installing without a duct connection, the damper should be fitted with an incombustible grille. Please note that from size  $\text{Ø}250$  mm onwards the damper blade goes outside the casing in the open position.
5. The duct system is fitted in accordance with current requirements. Ensure that suspension and duct systems do not affect the movement of the damper blade.
  - Damper for installation in walls and floors.
  - The shortest distance between dampers must be 200 mm.
  - The minimum distance to the connecting structure should be 75 mm.
  - Free position on damper spindle.





Installation instruction

**Installation in floors or joist systems.**  
**Damper's fire resistance class: EI60 (ve ho i <-> o) S.**  
**EG certificate 0402-CPR-C500380**  
**UKCA certificate 2822-UKCA-CPR-0135**

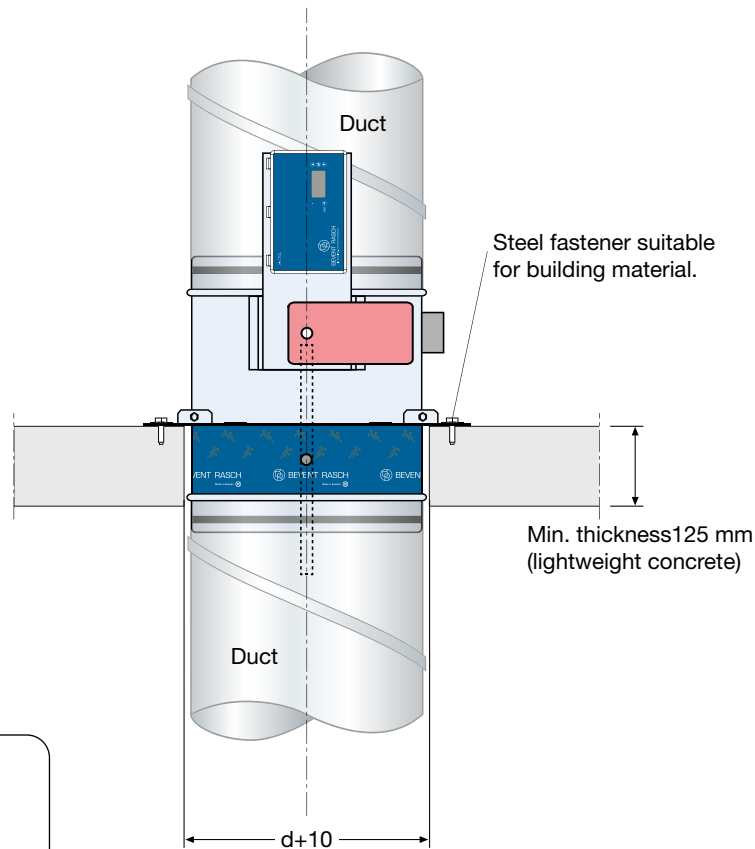

- Installation from one side
- No fire sealant
- No insulation strip
- No refinishing

1. Make a hole for size in question (d + 10 mm).
2. Attach the damper to the duct and secure the mounting ring flat against the building element. Use the appropriate fastener for the building material in question. Make sure that the shape of the damper is not impacted during installation.
3. If necessary, the damper can be rotated after installation by loosening the screws in the mounting ring. Turn the damper to the desired position and lock the screws.  
The actuator can be rotated to the desired position.
4. When installing without a duct connection, the damper should be fitted with an incombustible grille. Please note that from size Ø250 mm onwards the damper blade goes outside the casing in the open position.
5. The duct system is fitted in accordance with current requirements. Ensure that suspension and duct systems do not affect the movement of the damper blade.
  - Damper for installation in floors or joist systems.
  - The shortest distance between dampers must be 200 mm.
  - The minimum distance to the connecting structure should be 75 mm.



## Installation instructions

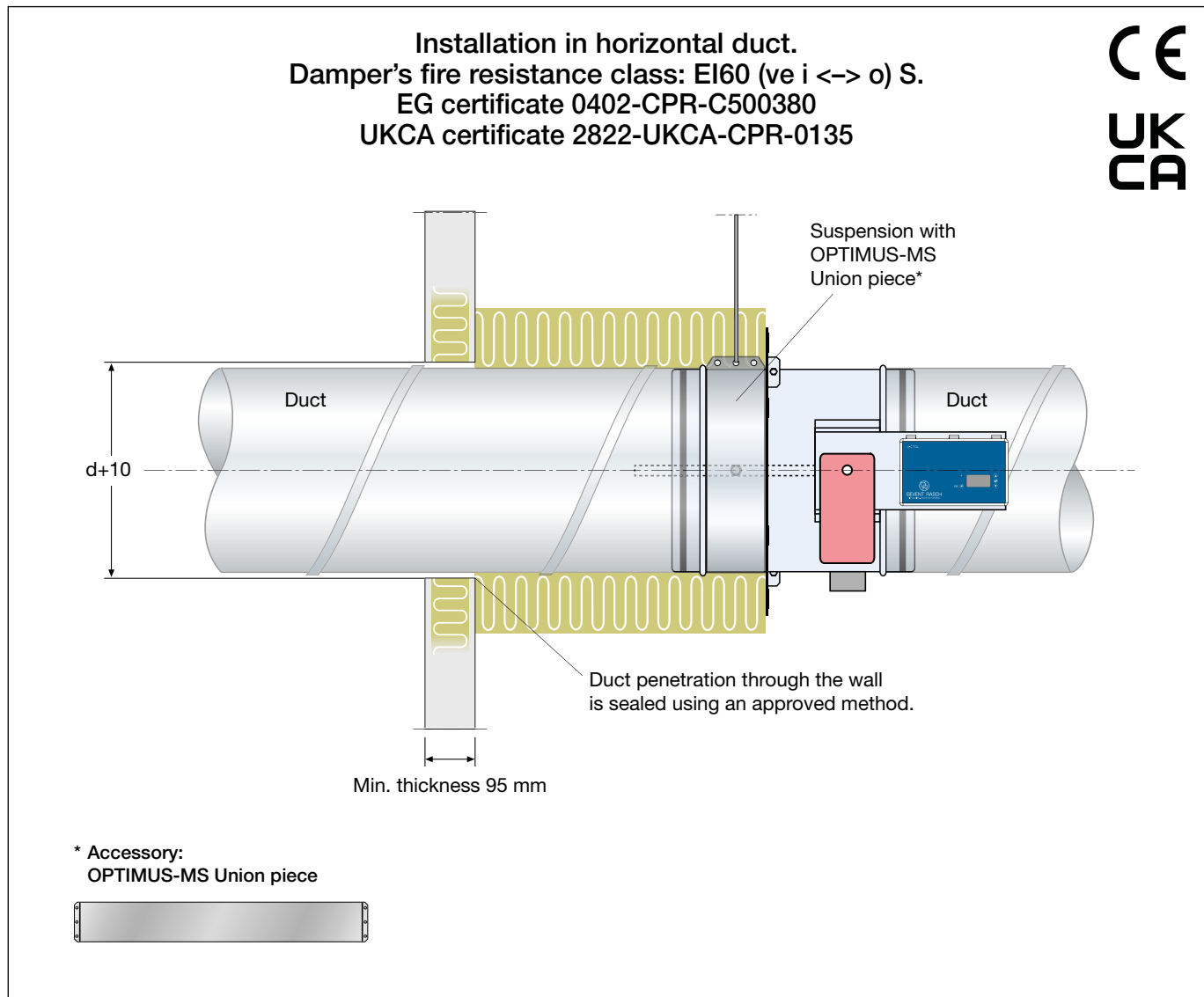

1. Make a hole for size in question ( $d + 10$  mm).
  2. Seal the wall penetration according to the circular ventilation duct method.
  3. Install the OPTIMUS-MS union piece accessory over the decal on the damper casing.
  4. When installing without a duct connection, the damper should be fitted with an incombustible grille.
  5. Insulate the duct from the wall penetration up to the damper's mounting ring. Insulate the EI60 duct system according to the supplier's instructions.
  6. The duct system is fitted in accordance with current requirements. Ensure that suspensions and duct systems do not affect the shape of the damper or impede the movement of the damper blade.
- Damper for installation in horizontal duct systems.
  - The shortest distance between dampers must be 200 mm.
  - The minimum distance to the connecting structure should be 75 mm.
  - Free position on damper spindle.



Installation instructions

**Installation in shaft walls**  
**Damper's fire resistance class: EI60 (ve i → o) S.**  
**EG certificate 0402-CPR-C500380**  
**UKCA certificate 2822-UKCA-CPR-0135**

\* Accessory:  
**OPTIMUS-SK Shaft ring**

– No sealant  
 – No insulation strip  
 – No refinishing

1. Make a hole for size in question (d + 10 mm).
  2. Install the OPTIMUS-SK shaft ring accessory between the damper's mounting ring and the wall. Secure the damper with an appropriate fastener for the building material in question. Make sure that the shape of the damper is not impacted during installation.
  3. If necessary, the damper can be rotated after installation by loosening the screws in the mounting ring. Turn the damper to the desired position and lock the screws. The actuator can be rotated to the desired position.
  4. When installing without a duct connection, the damper should be fitted with an incombustible grille.
  5. The duct system is fitted in accordance with current requirements. Ensure that suspension and duct systems do not affect the movement of the damper blade.
- Damper for installation in shaft walls.
  - The shortest distance between dampers must be 200 mm.
  - The minimum distance to the connecting structure should be 75 mm.
  - Free position on damper spindle.