

# BSK120

Rectangular Fire damper



FIRE SAFETY



CE  
UK  
CA

26/09/2024



### Quick facts

- Fire resistance class EI120 /EI120S
- Sizes from 200 x 200 mm to 1200 x 1000 mm
- Prefitted safety actuator 24V or 230V
- Available in MagiCAD
- CE-marked building product according to 15650:2010

### Use

Damper in combination with walls or joist systems for fire separation of heating, ventilation and air conditioning installations in buildings. In accordance with the harmonised European standard EN 15650:2010. In designs according to associated documents, installation instructions and when the damper is used in combination with smoke detectors and monitoring system (MRB), or the like, the spread of fire/combustion gases is prevented. No further action against the spread of fire/combustion gases is required.

### Performance

EC and UKCA certificate according to EN 15650:2010  
**0402-CPD-SC0206-13**  
**2822-UKCA-CPR-0133**

Classification of fire resistance according to EN 13501-3

**EI 120 (ve ho i <-> o) S**

For complete classification, see the Declaration of Performance.



### Installation

BSK120 is installed in fire cell separating walls or joist systems, according to the adjoining installation instructions. Should not be installed outdoors or in damp areas.

### Actuator

BSK120 is always supplied with an electric safety actuator with spring return complete with thermal sensor with pushbutton for local manual operating test. The sensor disconnects the power to the actuator if the temperature exceeds 72 °C inside or outside the damper. 24V actuators are always used in connection with the MRB monitoring system. Dampers can also be supplied with electric actuator 230V. Note that the BSK120 damper is always supplied with an actuator.



## Activation

According to Boverket's Building Regulations smoke detectors must be verified according to SS-EN 54-7 to activate dampers. The mandatory thermal sensor closes the damper at 72 °C according to ISO 10294-4.

## Control and monitoring

When the damper is used to prevent the spread of fire and combustion gases it must be closed via impulses from the smoke detector. This must be fitted in the ventilation duct in the proximity of the damper or in another suitable location. Smoke detectors are monitored by means of Rasch's MRB system or the like. The MRB monitoring system also performs automatic operating checks on the damper every 48 hours and is designed so that faults are indicated immediately and the damper closes.

See [www.bevent-rasch.se](http://www.bevent-rasch.se) for further details.

**Sizes** 200 x 200 up to 1200 x 1000 mm

## Design

The BSK120 damper is supplied complete with factory mounted, maintenance-free, 24V electric safety actuator with thermal sensor (unless otherwise stated) and built-in signal contacts to indicate the damper position. BSK120 is available in slip joint or flanged designs. Supplied as standard without inspection hatches.

## Material and surface finish

Casing and components of galvanized steel sheet according to environmental class C3. Other materials are available for higher environmental requirements. Damper blade of solid fire protection materials.

## Accessories

<b>BRAS</b>	Connection spigot for spiral duct
<b>RBFS</b>	Extension spigot for wall/joist systems thicker than 280 mm, and in combination with BRAS or wire mesh grilles
<b>RBMP</b>	Assembly plate, excl. refinishing material (RBBM), for installation in plaster structures EI 60 / EI 120
<b>RCKB</b>	Connection box
<b>RCDU</b>	MRB system, max 2 dampers
<b>RCBK4</b>	MRB system, max 4 dampers
<b>RCMU8</b>	MRB system, max 8 dampers
<b>RCKD/-RD</b>	Smoke detectors
<b>BRTR</b>	Wire mesh grille, rectangular
<b>BRTO</b>	Wire mesh grille, circular
<b>RCTU/RCTC</b>	MRB3 system, max 236 dampers
<b>FENIX2</b>	max 2 dampers
<b>FENIX4 / FENIX+</b>	max 16 dampers



### Specification

Example:  
**Fire damper**                    **BSK120 - 500 - 400 - 1 - 1 - 1 - 0**

*Size*  
 Width x Height (B x H), mm

*Connection*  
 Slip joint = 1  
 Flange = 2

*Material*  
 Hot-dip galvanized sheet steel = 1  
 Stainless AISI 316L – EN 1.4404 = 3

*Actuator*  
 Electric 24 V AC/DC with thermal sensor = 1  
 Electric 230 V AC with thermal sensor = 3

*Note! Factory fitted actuator always included.*

*Inspection hatches*  
 Without = 0  
 With = 1

### Accessories

**Connection spigot BRAS**  
 See specification, Accessories.

**Extension spigot RBFS - 2 - 500 - 400 - 1 - 1**

*Spigot length*  
 L = 155 mm = 1  
 L = 330 mm = 2

*Size*  
 Width x Height (B x H), mm

*Connection*  
 Slip joint = 1  
 Flange = 2

*Material*  
 Hot-dip galvanized sheet steel = 1  
 Stainless AISI 316L – EN 1.4404 = 3

**Assembly plate RBMP - 500 - 400 - 1**

*Size*  
 Duct, Width x Height (B x H), mm

*Material*  
 Hot-dip galvanized sheet steel = 1  
 Stainless AISI 316L – EN 1.4404 = 3



Dimensions and weight

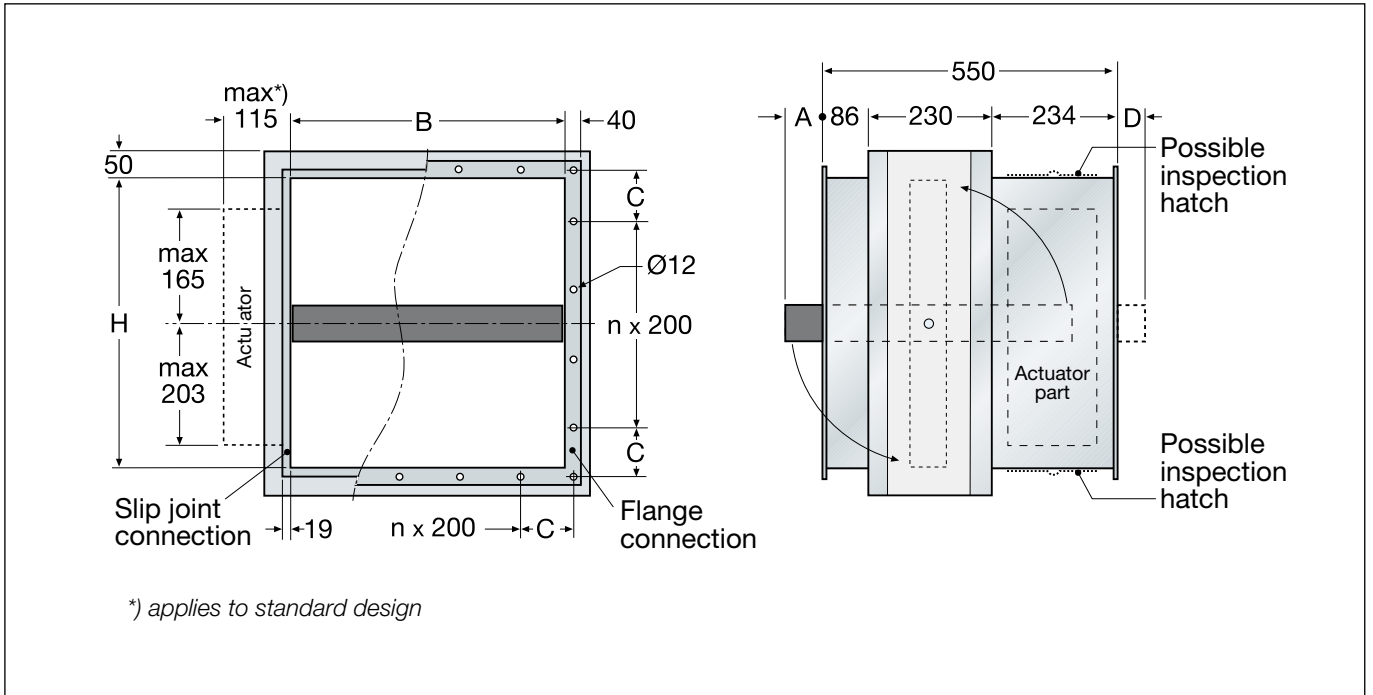

Dimensions, mm

W or H	C	Number of holes n
200	120	0
250	145	0
300	170	0
350	195	0
400	120	1
450	145	1
500	170	1
600	120	2
700	170	2
800	120	3
900	170	3
1000	120	4
1100 <sup>1)</sup>	170	4
1200 <sup>1)</sup>	120	5

<sup>1)</sup> Only applies to B-measurement

H	A	D
200	0	0
250	0	0
300	0	0
350	0	0
400	0	0
450	25	0
500	50	0
600	100	0
700	150	0
800	200	50
900	250	100
1000	300	150

Weight incl. 24 V actuator, kg

H	W												
	200	250	300	350	400	450	500	600	700	800	1000	1100	1200
200	18	20	21	23	25	26	28	32	35	38	45	48	52
250	20	21	23	25	27	28	30	34	37	41	48	52	55
300	21	23	25	27	29	31	33	37	40	44	51	55	59
350	23	25	27	29	31	33	35	39	43	46	54	58	62
400	25	27	29	31	33	35	37	41	45	49	58	62	66
450	26	28	31	33	35	37	39	44	48	52	61	65	69
500	28	30	33	35	37	39	41	46	51	55	64	69	73
600	33	35	38	40	42	45	47	52	57	62	71	76	81
700	36	38	41	44	46	49	52	57	62	67	78	83	88
800	39	42	45	47	50	53	56	62	67	73	84	90	95
1000	46	49	52	55	59	62	65	71	78	84	97	103	109



Installation

**Connection spigot  
BRAS**

**Extension spigot  
RBFS**

BRAS Ød	Min. damper size	A	RBFS	
			L <sub>1</sub>	L <sub>2</sub>
100	200 x 200	50	-	-
125	200 x 200	50	-	-
160	200 x 200	50	-	-
200	200 x 200	50	-	-
250	250 x 250	50	-	-
315	350 x 350	65	-	-
400	400 x 400	80	-	-
500	500 x 500	80	155	-
630	650 x 650	80	155	-
800	800 x 800	100	330	155
1000	1000 x 1000	100	330	330

\*) Length as per the table above

Assembly plate RBMP (incl. in delivery)

RBMP supplied unassembled



**Technical data**

**Sound data**

The speed is calculated on the damper's gross area, i.e. a

BSK120 - 400 x 400 has a gross area of 0.16 m<sup>2</sup>.

The specified pressure drop applies to the damper without accessories.

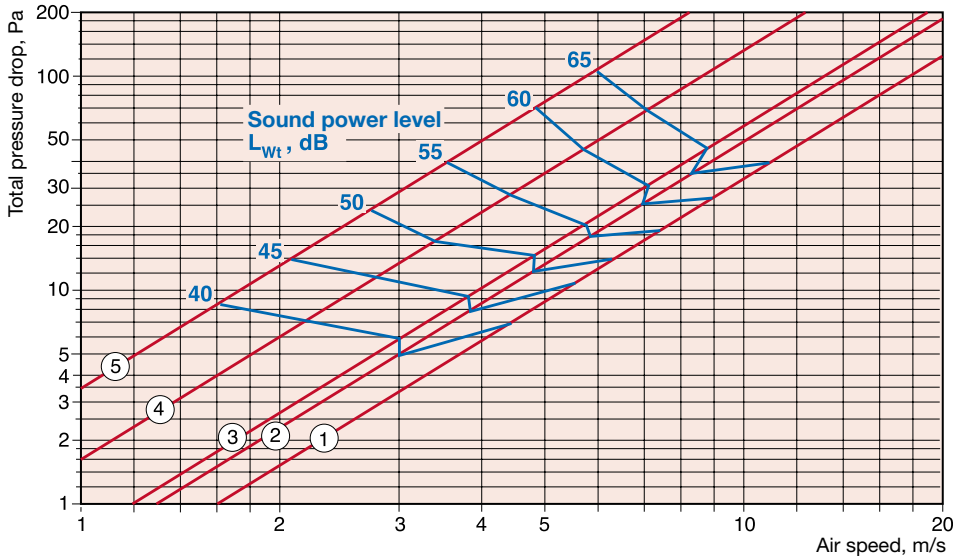

- ① Damper height H ≥ 400 mm
- ② Damper height H ≥ 350 mm
- ③ Damper height H ≥ 300 mm
- ④ Damper height H ≥ 200 mm
- ⑤ Damper 200 x 200 mm

Correction of sound power level,  $L_w$ , for different sizes

use curves ① - ④ according to:  $L_w = L_{wt} + K_1$

Damper height mm	Damper area, m <sup>2</sup>				
	0,08	0,16	0,32	0,64	1,28
≥400 as per ①	0,08	0,16	0,32	0,64	1,28
350 as per ②	0,07	0,14	0,28	-	-
300 as per ③	0,06	0,12	0,24	-	-
200 as per ④	-	0,08	0,16	-	-
$K_1$	-3	0	3	6	9

Correction of sound power level,  $L_{ok}$ , in octave band

$$L_{wok} = L_w + K_{ok}$$

Correction,  $K_{ok}$

Opening angle	Centre frequency Hz							
	63	125	250	500	1K	2K	4K	8K
90°	-3	-4	-8	-10	-14	-14	-16	-20
Tol. ± dB	3	3	2	2	2	2	2	3

**Electrical data** (values in brackets refer to 230 V)

Actuator type BF... BLF...  
 Sizing, max ..... 10 VA (12,5 VA) 7 VA (7 VA)

Running time;  
 - motor opening, max ..... ca 140 s 40-75 s  
 - spring return, max..... ca 20 s

Protection class ..... IP 54

Power supply ..... 24V~ ±20%, 50/60Hz  
 24V= ±10%  
 (220-240V~, 50/60Hz)

Ambient temperature ..... -30° to +50°C

Safety temperature ..... -30° to +75°C  
 (24 hrs. guaranteed safety)

Tripping temperature with thermal sensor ..... 72°C

End position contacts  
 - load ≤ 300 mW ..... min 1 mA/5V=, max 100 mA/250V~

After exceeding the above values it applies:

- load > 300 mW ..... min 100 mA, max 3 A/250~

Sound level when opening approx 45 dB(A)

Sound level when closing approx 62 dB(A)

**Wiring diagram**

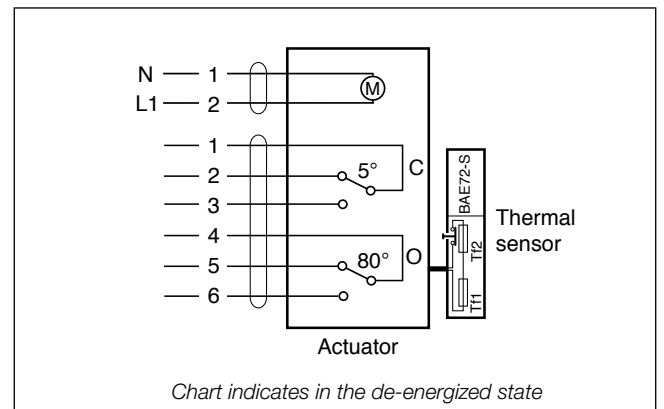



Installation instructions

Building element (wall or joist structure) in fire resistance class EI120.
Damper's fire resistance class: EI120 (ve ho i <-> o) S.
EC certificate SC0206-13
UKCA certificate 2822-UKCA-CPR-0133



Option 1 Wall\*)

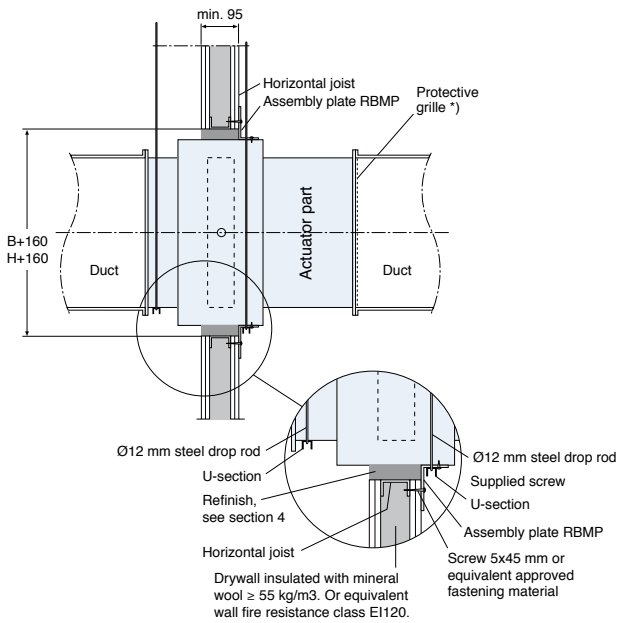

Option 2 Joist system

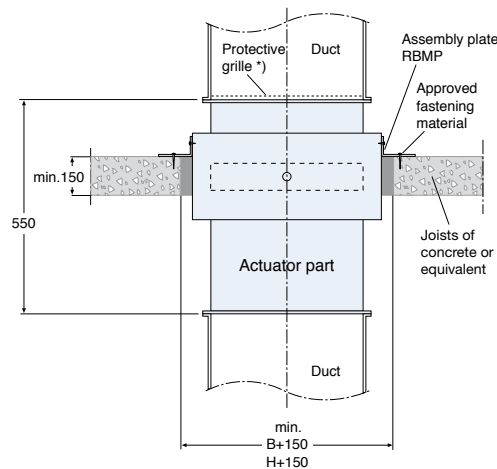
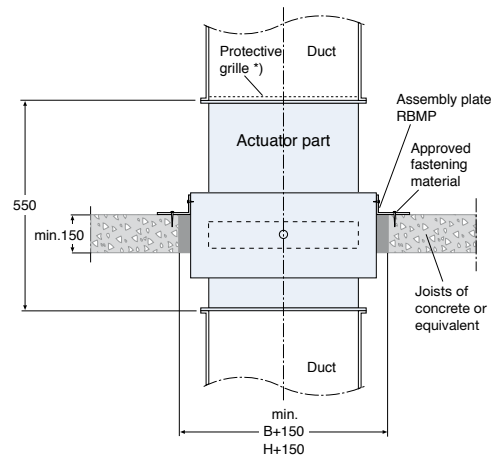

Options 1 and 2

- 1. Joists should be supported horizontally and when applicable vertically so that the desired opening is obtained.
2. Fit the assembly plates RBMP on the damper using the supplied screws so that the damper blade is inside the building element when installed. RBMP is reversible.
3. The damper is centred in the opening and screwed in position through the assembly plates RBMP and the wall studs.
4. Refinish with mineral wool ≥ 55 kg/m³

- 5. Install the duct system according to applicable requirements. Make sure that the connected duct system does not impact on the damper in the event of a fire load.

\*) If the fire damper is not connected to the duct system, fit non-combustible grilles designed for the damper on the unconnected sides. The minimum distance between the damper blade in the open position and the grille is 50 mm.

- Minimum distance between dampers must be 200 mm.
• Minimum distance to joist structure/wall must be 75 mm.
• Horizontal installation of the damper spindle.